

# YAMAHA

# RB30

System Rack & Patch Bay Unit

Patch Bay Unit

# PB44

## OWNER'S MANUAL

### INTRODUCTION

*Thank you for selecting the Yamaha Producer Series RB30 Multitrack System Rack and PB44 Patch Bay Unit. These products have been specially designed to complement the MM30 and MT44 Producer Series components, and will make their use even more convenient by facilitating connections and use of selectors for multitrack recording ("ping-ponging," mixing, etc.). The superior technology, workmanship and finish of RB30 and PB44 will enhance both the operation and appearance of your studio.*

### CAUTIONS

- Do not expose the RB30/PB44 to direct sunlight or other sources of heat such as radiators, etc.
- Do not attempt to clean the RB30/PB44 with benzine or other solvents as these may cause discoloration or deformation of the cabinet. Clean the unit with a soft, dry cloth.
- For more convenient and accurate connecting, an identification label is attached to the plug end of each cord which leads from the components. Use these identification labels to ensure correct connection.

## PATCH BAY UNIT OPERATION

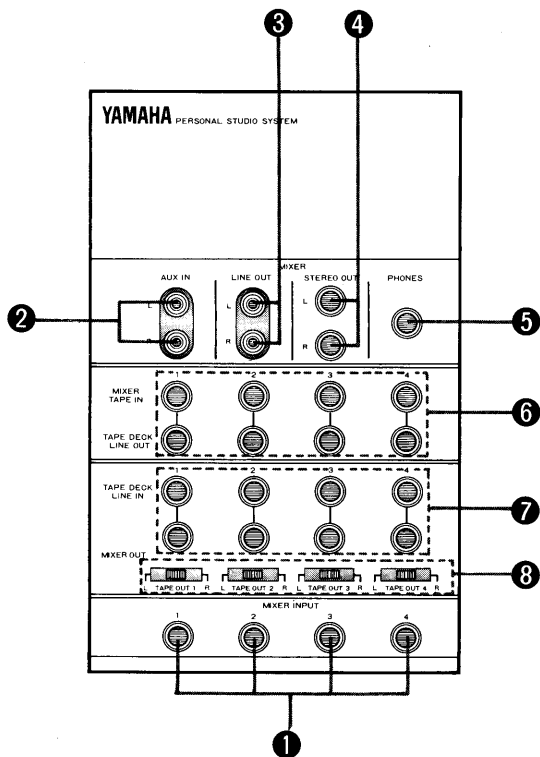

### 1 INPUT

For connection of microphones or electric (electronic) musical instruments. Input to these terminals is sent to the MM30's Input.

### 2 AUX IN

For connection of a tape deck or additional mixer (sub mixer).

### 3 LINE OUT

The MM30's Line Out signal; when connected to a stereo tape deck, it can be used to mix down multiple recording sources from the MT44.

### 4 STEREO OUT

Sends output signals mixed by the MM30 to Stereo Out. Also serves as an output monitor terminal with connection of MS10 (powered speaker).

### 5 PHONES

For connection of stereo headphones; also serves as a monitor terminal when recordings are being done from the microphone.

### 6 REPLAY SYSTEM ACCESSORY TERMINAL

This is installed between the MT44's Line Out and the MM30's Tape In. When plugged into the Mixer Tape In, that channel's inner circuitry is cut and the Mixer Tape In signal goes to the MM30's Tape In. Thus it is used when changing channel sequencing or for effects when using channels independently. It can also be used for making inserts between the Tape Deck Line Out and the mixer Tape In, or to make replays to Mixer Tape In when connected to a tape deck instead of the MT44.

### 7 RECORDING SYSTEM ACCESSORY TERMINAL

This is installed between the MM30's Tape Out and the MT44's Line In for installation of accessories. When connected to Tape Deck Line In, that channel's circuitry is cut and the Tape Deck Line In signal is sent to the MT44's Line In. Or it can be connected between Mixer Out and Tape Deck Line In for using compressors, echo machines, graphic equalizers, etc., independently on each channel.

### 8 MIXER OUT SELECTOR

Setting of this selector determines the recording mode of the MT44.



Normally, the selector is in this position—the MM30's Tape Out signal is sent to the MT44's Line In terminal—which is used to make recordings on each track without mixing.



In this position, a mixed L signal is sent from the MM30's Stereo Out to the MT44's Line In. When the selector is in this position, a variety of mixed signals can be recorded on each track, and ping-pong recordings (back and forth) can be made.



In this position, a mixed R signal from the MM30's Stereo Out is sent to the MT44's Line In terminal. This produces the same effect as mentioned above.

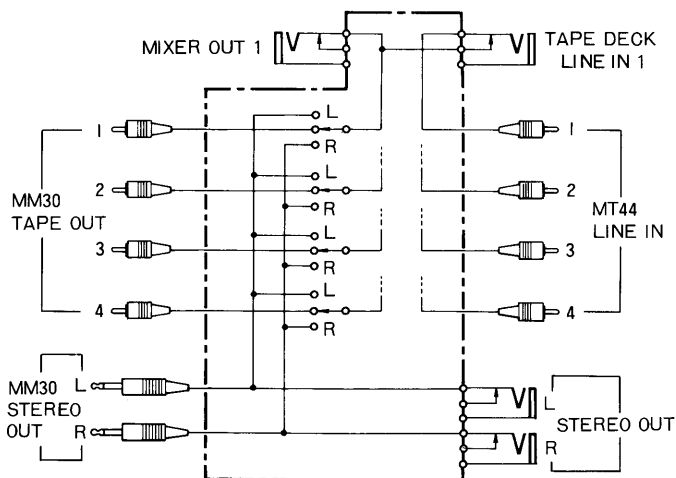

# MULTITRACK RECORDING

● Case 1

To record 4-track without mixing

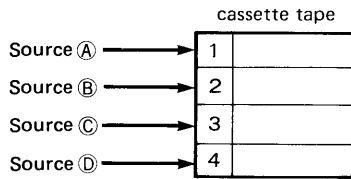

★ To record sources 1 ~ 4 individually without mixing, set Mixer Out Selectors 1 ~ 4 all in the Tape Out position.

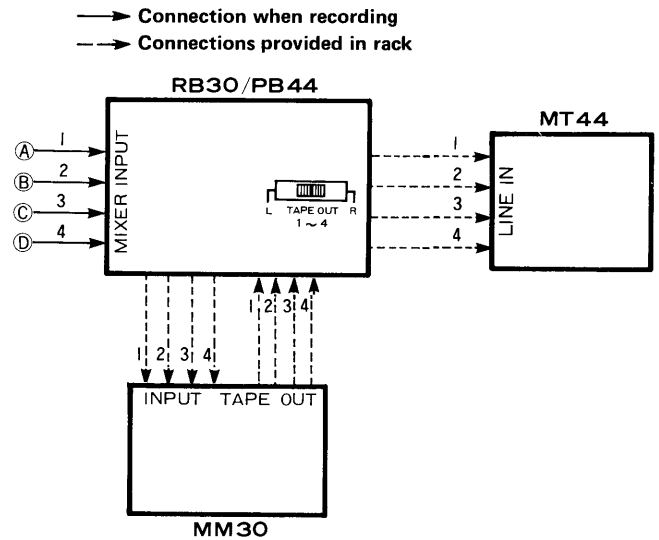

● Case 2

To make 2-track recordings

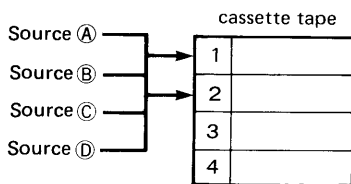

★ To make separate L and R 2-track recordings with the MT44 using PAN (panpot), first set the stereo orientation, then set Mixer Out selector 1 in the L position and Mixer Out selector 2 in the R position.

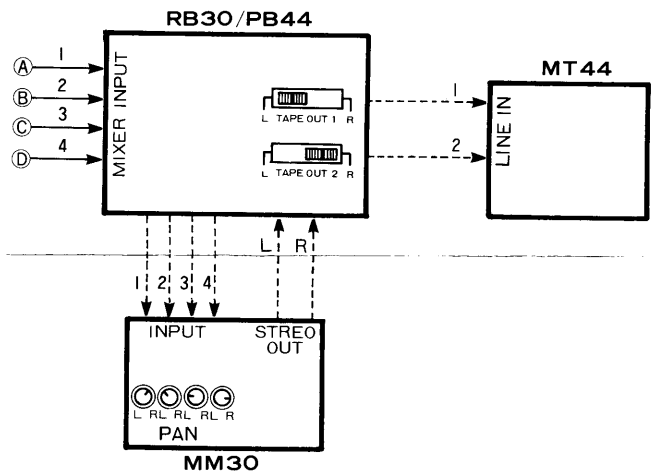

● Case 3

To make ping-pong recordings

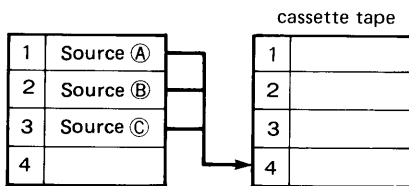

★ In "ping-ponging," recorded tracks are mixed and transferred to an unrecorded track to open up these tracks for further recording. As shown in the diagram, sources 1 ~ 3 can be transferred onto track 4. To do this, adjust the volume of each source using the Input Fade, then set the Mixer Out selector for track 4 to L or R.

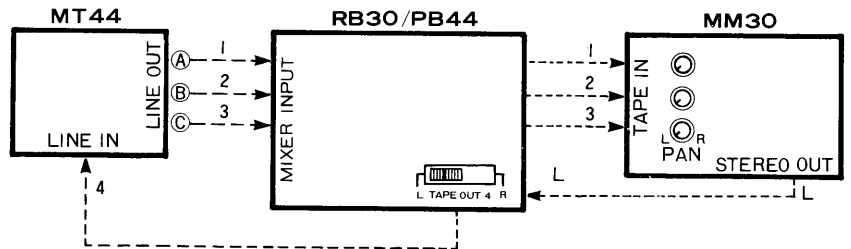

# RB30

## ASSEMBLY PROCEDURES

- Before assembly, check all parts against the parts list to confirm that none are missing.
- For assembly, only a Phillips  $\oplus$  screwdriver is required.

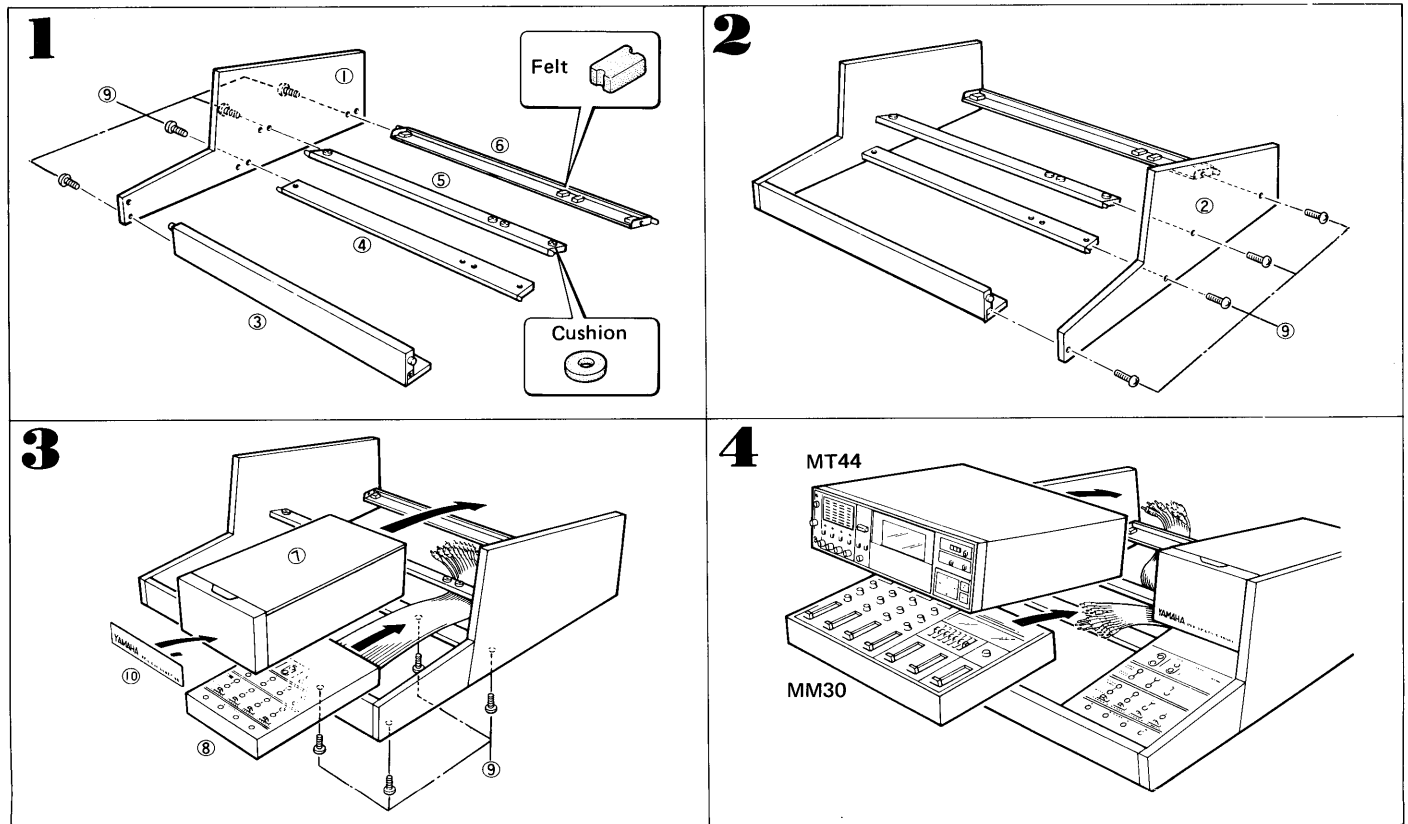

1. Install the front board (3) and the three stay boards (4), (5), (6) on the side board (1) and screw into place using four screws (9).
2. Install the other side board (2) in the same manner.
3. Route the cord from the back of the patch bay unit (8) between stay boards (4) and (5). Attach the patch board with four screws (9). Next attach the sticker (10) to the front of the accessory box (7) and place in the far right side of the rack. (See diagram)
4. Route the wiring from the MT44 and MM30 through the stay boards and place them in the rack. Next, connect the wiring from the patch bay unit to the MM30 and MT44. Before making connections, confirm the proper wiring order by referring to the attached label.

## VIEW OF ASSEMBLED SYSTEM

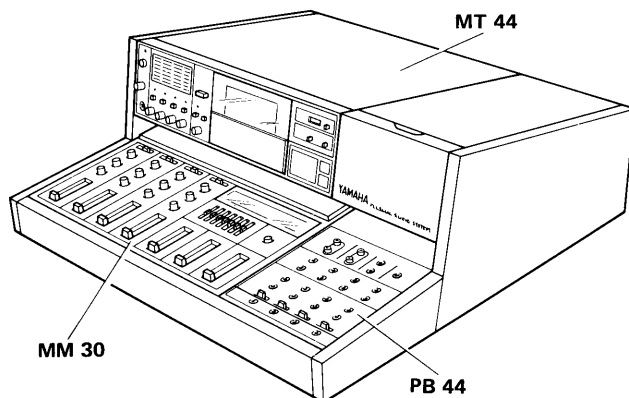

## • PARTS LIST

Part No.	Description	Quantity
①	Left Side Board	1
②	Right Side Board	1
③	Front Board	1
④	Stay A	1
⑤	Stay B	1
⑥	Stay C	1
⑦	Accessory Box	1
⑧	Patch Bay Unit (PB44)	1
⑨	Screws	12
⑩	Sticker	1

*\*If any parts are missing, please contact your Yamaha dealer.*

SINCE 1887



# YAMAHA

NIPPON GAKKI CO., LTD. HAMAMATSU, JAPAN

OMD-72

8342 Printed in Japan.