

**SINGLE  
KEYBOARD  
ORGAN**

**CNR-80**

**Owner's Manual**

**Bedienungsanleitung**

**Manuel de L'utilisateur**

**Manual del Propietario**

**Instruktionsbok**

# CNR-80

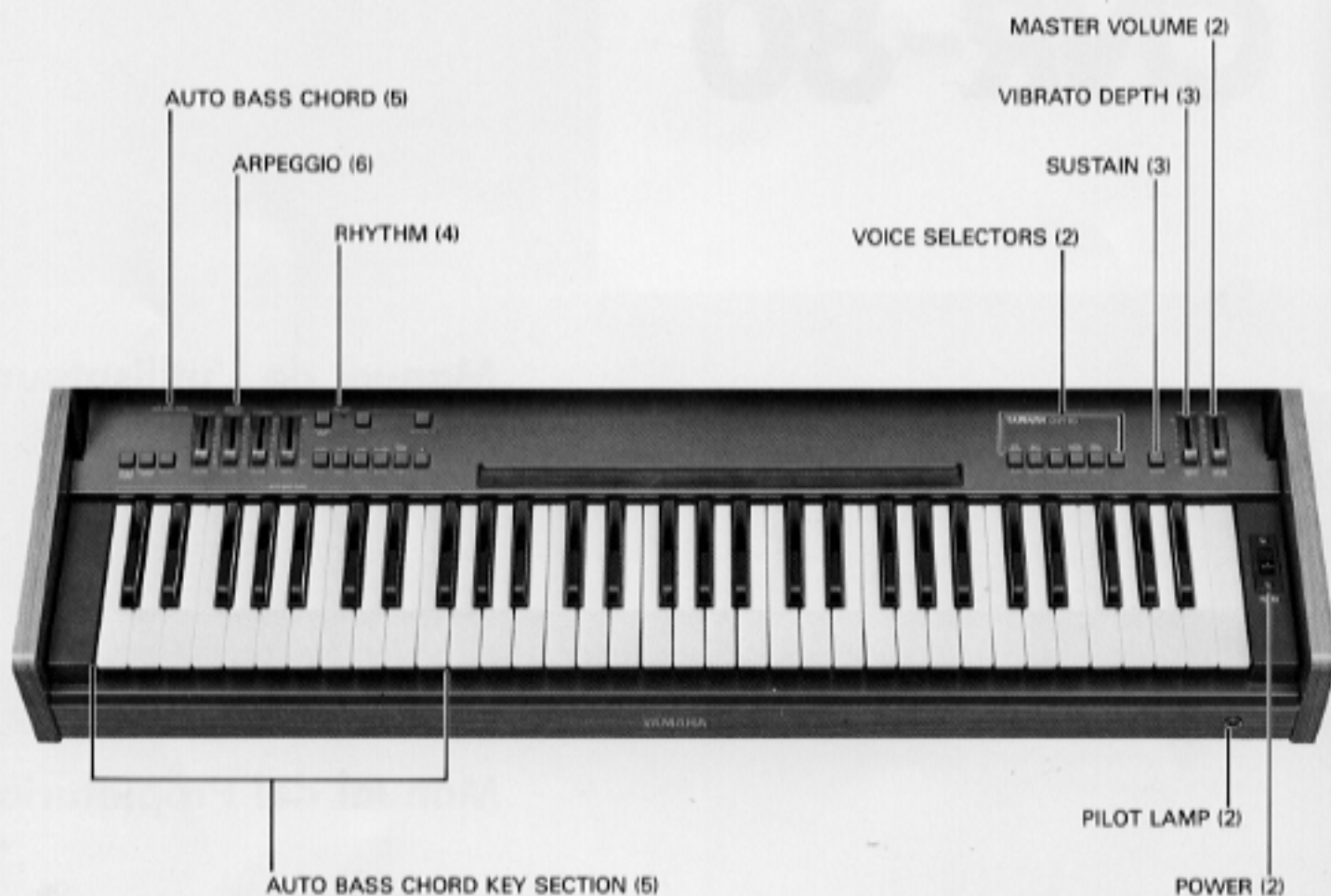

- The numbers in brackets indicate the pages in this manual where you will find an explanation of these parts and features.
- Die in Klammern angegebenen Zahlen beziehen sich auf die Seiten in dieser Bedienungsanleitung, auf denen Sie die Erklärung der betreffenden Teile und Funktionen finden.
- On trouvera de plus amples renseignements sur ces commandes et caractéristiques en consultant les pages indiquées entre parenthèses.
- Los números entre corchetes indican las páginas de este manual en las que encontrará las explicaciones sobre estas partes y características.
- Siffrorna inom parenteserna hänvisar till de sidorna i denna instruktionsbok, där du hittar förklaringarna på delarna och deras funktioner.

## Introduction

Thank you for purchasing a Yamaha CNR-80.

This instrument offers you the following advanced functions and features:

- A voice section using the FM (Frequency Modulation) Tone Generation for 10 kinds of high-quality sounds.
- A rhythm section with realistic percussion sounds based on the FWM (Full Wave Memory) Digital Tone Generation.
- Functions such as Auto Bass Chord and Arpeggio, which make playing easier and more fun.
- 61 standard-size keys on a wide-range keyboard.

Please read this manual thoroughly as you play and experiment with the instrument.

## Einführung

Herzlichen Glückwunsch zum Kauf der Yamaha CNR-80.

Dieses Instrument bietet die folgenden fortschrittlichen Funktionen und Merkmale:

- Einen Stimmteil, der mittels FM (Frequenz-Modulation)-Tongenerator 10 qualitativ hochwertige Klänge erzeugt.
- Einen Rhythmusteil mit realistischen Schlaginstrumentklängen, die auf FWM (Vollwellenspeicher) Digital-Tonerzeugung basieren.
- Funktionen wie Auto-Bass-Akkorde und Arpeggio, die das Spielen leichter und erfreulicher machen.
- 61 Normaltasten auf einer breiten Tastatur.

Bitte lesen Sie diese Bedienungsanleitung gründlich durch, während Sie mit dem Instrument spielen und experimentieren.

## Introduction

Nous tenons tout d'abord à vous remercier d'avoir porté votre choix sur le Yamaha CNR-80. Cet instrument vous offre les fonctions et caractéristiques avancées suivantes:

- Une section vocale qui utilise la génération de tonalités à modulation de fréquence (FM) pour 10 types de sons de haute qualité.
- Une section rythme, avec des percussions "réalistes", basées sur la génération d'une tonalité numérique FWM (Full Wave Memory).
- Des fonctions telles que l'accord automatique des graves et des arpèges, ce qui facilite l'utilisation et ajoute de l'amusement.
- 61 touches de format standard sur un grand clavier.

Prière de lire attentivement ce manuel au fur et à mesure que vous jouez et vous familiarisez avec l'instrument.

## Introducción

Gracias por haber adquirido un CNR-80 Yamaha.

Este instrumento dispone de las funciones y características avanzadas siguientes:

- Sección de voces que utiliza la generación de tonos de FM (modulación en frecuencia) para 10 tipos de sonidos de alta calidad.
- Sección de ritmos con sonidos de percusión realistas en la generación de tonos digitales de la FWM (memoria de onda completa).
- Funciones tales como acorde bajo y automático, y arpegio, que facilitan y hacen más divertida la ejecución.
- 61 teclas estándar en un teclado de amplia gama.

Lea detenidamente este manual cuando toque y experimente con el instrumento.

## Introduktion

Tack att du valde Yamaha CNR-80.

Detta instrument har följande, avancerade funktioner och finesser:

- En ljudsektion som använder en FM-krets (frekvensmoduleringskrets) för tonframställning av 10 sorters ljud med hög kvalitet.
- En rytmsektion med realistiska slaginstrumentljud tack vare fullvågformsminnet (FWM) med digital tonalstring.
- Funktioner som Auto Bass Chord (automatiskt bas- och ackordackompanjering) och Arpeggio (automatiskt, brutet ackord), vilka gör det lättare och roligare för Dig att spela på orgeln.
- 61 tangenter i standardstorlek på den omfångsrika manualen.

Läs noga igenom instruktionsboken samtidigt som Du spelar och experimenterar på ditt nya instrument.

## Contents

	page
● BEFORE PLAYING .....	2
● TO START PLAYING .....	2
● USING THE REALISTIC DRUMS .....	4
● ADDING BASS AND STRUMMING CHORDS .....	5
● USEFUL INFORMATION .....	7
● ASSEMBLY PROCEDURES .....	8
● SPECIFICATIONS .....	17

## Inhaltsverzeichnis

	Seite
● EHE SIE ZU SPIELEN BEGINNEN .....	2
● SPIELBEGINN .....	2
● DER EINGEBAUTE SCHLAGZEUGER .....	4
● ZUSÄTZLICHE BASS- UND AKKORDBEGLEITUNG .....	5
● PRAKTISCHE INFORMATIONEN .....	7
● AUFSTELLUNGSANLEITUNG .....	8
● TECHNISCHE DATEN .....	17

## Table des matières

	Page
● AVANT DE JOUER .....	2
● MISE EN ŒUVRE DE L'INSTRUMENT .....	2
● UTILISATION DE LA BATTERIE "REALISTE" .....	4
● ADDITION D'ACCORDS AVEC BASSES .....	5
● CONSEILS PRATIQUES A L'USAGE .....	7
● MANUEL DE MONTAGE .....	8
● CARACTERISTIQUES TECHNIQUES .....	17

## Contenido

	Página
● ANTES DE EMPEZAR A TOCAR .....	2
● PARA EMPEZAR A TOCAR .....	2
● UTILIZANDO LA BATERIA REALISTA .....	4
● ADICIÓN DE BAJO Y ACORDES RASGUEADOS .....	5
● INFORMACIÓN ÚTIL PARA EL MANEJO .....	7
● MANUAL DE MONTAJE .....	8
● ESPECIFICACIONES .....	17

## Innehåll

	Sida
● NÄR DU BÖRJAR SPELA .....	2
● INNAN DU BÖRJAR SPELA .....	2
● ANVÄND DE NATURTROGNA TRUMMORNA .....	4
● LÄGG TILL BAS OCH RYTMISKA ACKORD .....	5
● VÄRDEFULL INFORMATION .....	7
● MONTERINGSINSTRUKTIONER .....	8
● SPECIFIKATIONER .....	17

# BEFORE PLAYING

## Check for correct power voltage.

Consult your Yamaha serviceman regarding any changes. The power voltage is indicated on the nameplate at the back side.

First of all, make sure that the plug is firmly inserted in the wall power outlet, then:

### 1) Turn on the POWER.

The power indicator lamp will light up.

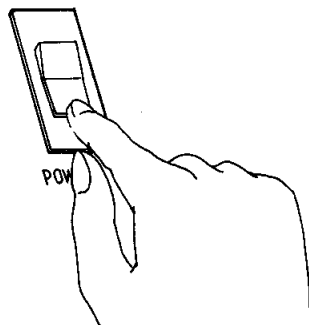

### 2) Slide the MASTER VOLUME control to the desired position.

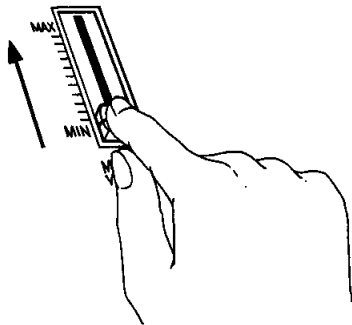

### 3) Depress the Expression Pedal.

The Expression Pedal is used to control volume during performance.

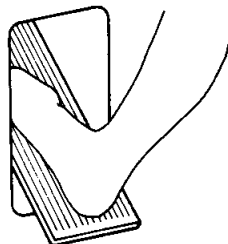

# TO START PLAYING

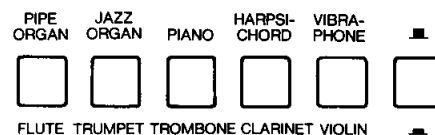

## VOICE SELECTORS

This organ can be played with 10 different voices.

### 1) Press the selector corresponding to the instrument voice you want to hear.

When the rightmost selector is in the "up" position (▲), you can select the voices indicated in the top row. When it is in the "down" position (▼), you can choose from the bottom row of voices.

### 2) Adjust the volume level by sliding the MASTER VOLUME control.

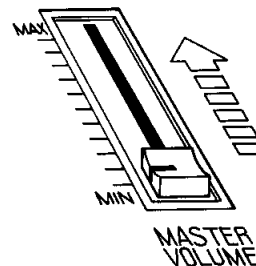

### 3) Press a key on the keyboard.

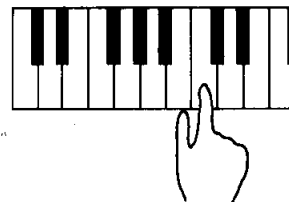

You will hear the instrument voice you have selected. Try playing a simple melody which suits the voice.

- ★ When two or more voice selectors are pressed simultaneously, the right-hand selector always has priority.
- ★ When no selector is depressed, the PIPE ORGAN voice will be automatically selected.



SUSTAIN

## SUSTAIN

The Sustain function gives the notes a natural or gradual fade-out after the keys have been released. A Sustain effect can be obtained by pressing the SUSTAIN button.

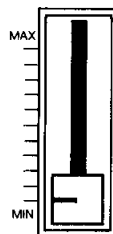

VIBRATO DEPTH

## VIBRATO DEPTH

Vibrato is a variation in pitch, a fluctuation above and below whatever note is being pressed. A Vibrato effect can be obtained by sliding the VIBRATO DEPTH control forward MAX.

- ★ The Vibrato effect used in the CNR-80 is a delayed vibrato, meaning it will begin to be effective a short while after a key has been pressed.
- ★ The Vibrato effect cannot be used with the voices PIANO and HARPSICHORD.

Try playing the following melodies.

PIPE ORGAN



VIBRAPHONE

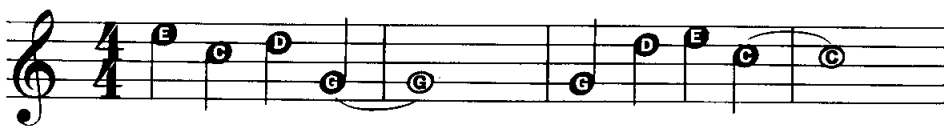

TRUMPET

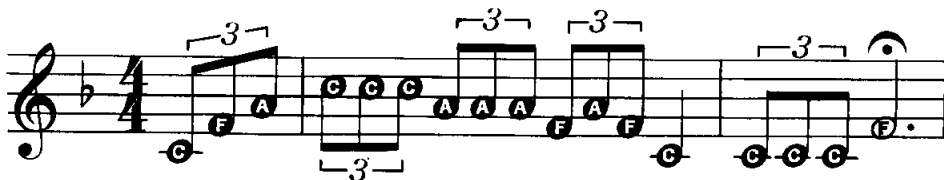

CLARINET

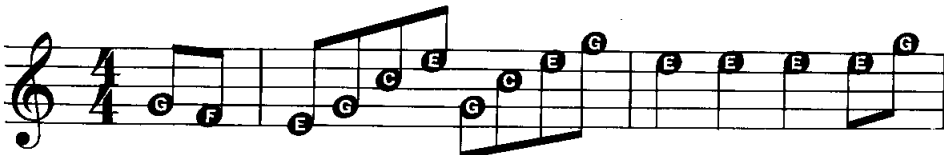

VIOLIN

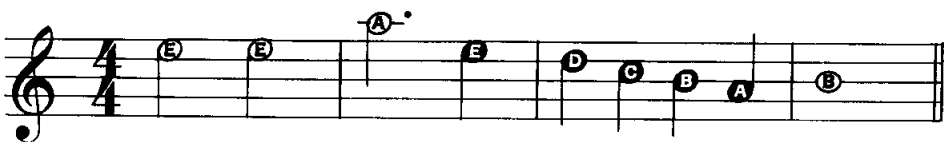

# USING THE REALISTIC DRUMS

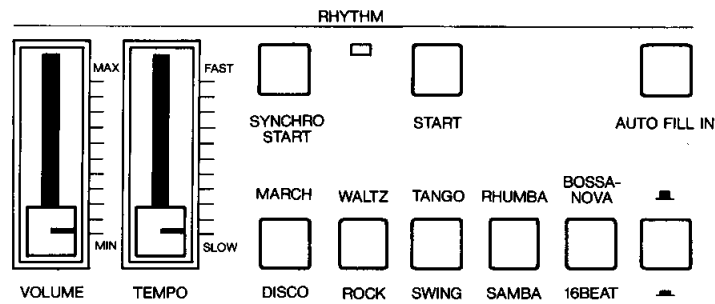

## RHYTHM

Now let's add a rhythm accompaniment to your melody.

### 1) Choose a rhythm.

Pick the rhythm which best suits the music you're going to play and press the selector.

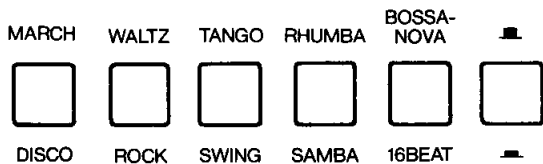

When the rightmost selector is in the "up" position (■), you can select the rhythms indicated in the top row. When it is in the "down" position (▾), you can choose from the bottom row of rhythms.

### 2) Start the rhythm.

After selecting a rhythm, press the START selector.



To stop the rhythm, press the START selector again.

### 3) Adjustments.

#### Volume

The Rhythm VOLUME control allows adjustment of the rhythm volume in relation to the melody volume.

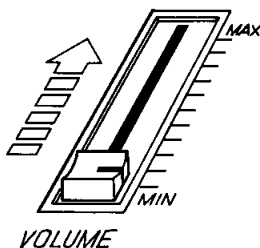

#### Tempo

Use the TEMPO control to adjust the tempo of the rhythm.

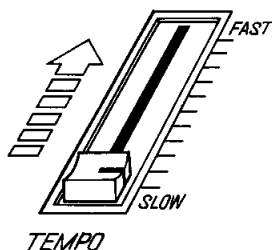

### ● SYNCHRO START



The SYNCHRO START selector is used when you want to have the rhythm begin the moment a key is depressed. The first 19 keys on the left side of the keyboard, which are identified by the words AUTO BASS CHORD printed above the keys, will activate the rhythm sounds. When a key has been depressed in this section, the rhythm will continue until it is turned off by pressing the SYNCHRO START selector again.

### ● TEMPO LAMP

The Tempo Lamp functions as a visual metronome, making it simple for you to confirm the rhythm tempo when playing a melody. When a rhythm is activated, the lamp flashes at the first beat of every bar. When the SYNCHRO START selector is engaged but you have not yet started the rhythm by pressing a key, the Tempo Lamp flashes at every quarter note.

### ● AUTO FILL IN



AUTO FILL IN

This function automatically changes the rhythm and accompaniment patterns after a certain number of measures. When this button is pressed to ON, the rhythm pattern is switched to a fill in pattern every 4 measures, while the chord, bass and arpeggio patterns are switched to fill in patterns every 8 measures.

- ★ When two or more voice selectors are pressed simultaneously, the right-hand selector always has priority.
- ★ When no selector is depressed, March will be automatically selected.

# ADDING BASS AND STRUMMING CHORDS

AUTO BASS CHORD

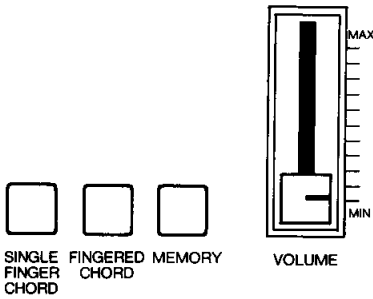

## AUTO BASS CHORD

The AUTO BASS CHORD is an automatic accompaniment feature. When the single finger chord selector is depressed, you can play three-note chords using a single finger. The FINGERED CHORD selector allows more experienced players to play their own chords while continuing to get the bass and rhythm back-up.

### SINGLE FINGER CHORD

1) Press the SINGLE FINGER CHORD selector.



2) Set the volume.

Adjust the volume to suit the overall level using the Auto Bass Chord's independent VOLUME control.

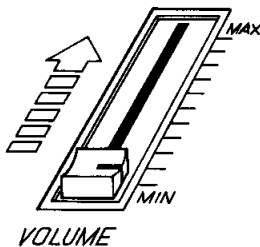

3) Select a rhythm.

Choose the rhythm you want, then press the SYNCHRO START or START selector. (Don't forget to do this whenever you use the Auto Bass Chord feature)

4) Press a key.

Press one of the 19 keys in the Auto Bass Chord key section on the left side of the keyboard. You will hear the corresponding chord with bass and rhythm accompaniment. For instance, when you press "C" ("Do"), you'll obtain a C major chord that strums along with the bass and rhythm.

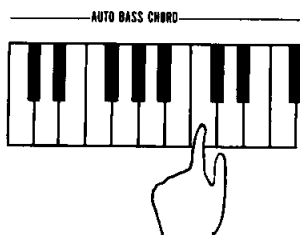

● **Obtaining minor, seventh and minor seventh chords.**  
You can play a total of 48 chords (4 types × 12) in Single Finger Chord mode.

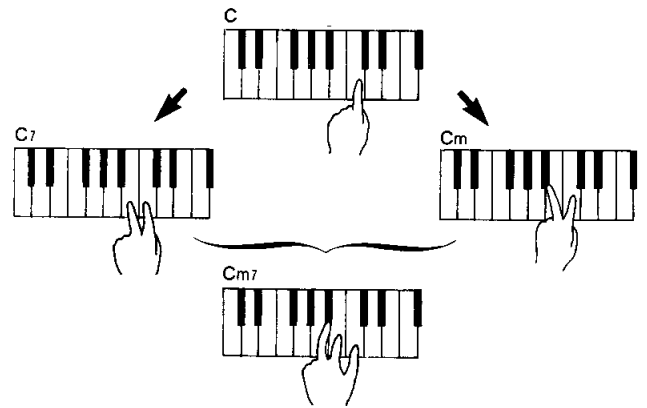

- To get a C minor chord, depress the C key together with the next black key to the left.
- To get a C seventh chord, depress the C key together with the next white key to the left.
- To get a C minor seventh chord, simply press the C key together with the next black key and white key to the left.

● **MEMORY**



MEMORY

This function is convenient when you change chords. If this selector is pressed when the Single Finger Chord or Fingered Chord mode is used, the bass pattern and the strumming chords will continue to play after you lift your finger(s) from the keys. Therefore, you only have to press the keys when you change chords. If you prefer to hold down chords, you must completely lift your finger(s) from the keys when you change from one chord to another, otherwise the chord will not change correctly.

- ★ When the AUTO FILL IN button in the rhythm section is pressed to ON, the chord and bass patterns are automatically switched to fill-in patterns every 8 measures. (See page 4.)
- ★ When the Auto Bass Chord feature is used without SYNCHRO START or START, you will get a continuous chord with bass.

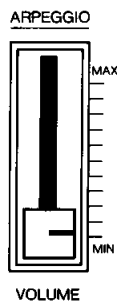

## ARPEGGIO

This section provides an effect similar to those produced by an experienced keyboard player playing runs or progressions of notes up and down the keyboard in a rippling effect.

This effect can be activated when the Rhythm section and either the Single Finger Chord or Fingered Chord mode are being used. To use the Arpeggio effect, first play a note or a chord in the Auto Bass Chord key section. You will hear the Arpeggio by sliding the ARPEGGIO VOLUME control towards MAX. Adjust the sound level to your personal preference. To stop the Arpeggio effect, slide the lever to MIN.

★ *When the AUTO FILL IN button is pressed to ON, the arpeggio pattern is automatically switched to a fill-in pattern every 8 measures. (See page 4.)*

### FINGERED CHORD

- 1) Press the FINGERED CHORD selector.



FINGERED CHORD

- 2) Set the volume.
- 3) Select a rhythm.
- 4) Press a chord.

When a combination of keys located in the Auto Bass Chord key section are pressed, the resulting chord will be played together with the automatic accompaniment consisting of the bass line and the selected rhythm.

- ★ *In the Fingered Chord mode, the following chords can be played: major, minor, seventh, minor seventh, minor seventh flatted fifth, seventh suspended fourth.*

### Playing a melody backed by automatic accompaniment

#### When The Saints Go Marching In

Chord progression: No Chord, C, C, G, G, C, F, F, C, G, C, F, C, G, C

Lyrics:  
 Oh, when the Saints go march-ing in,  
 Oh, when the Saints go march-ing in,  
 I want to be in that num-ber,  
 When the Saints go march-ing in.



# USEFUL INFORMATION

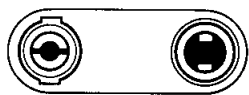

AUX. OUT HEAD  
PHONES

## ACCESSORY JACKS

### ● HEADPHONES jack

This jack is used for connecting a pair of monaural headphones. When the headphones are connected, no sound will be produced from the CNR-80's speaker. This allows you the freedom to enjoy playing your instrument at any time without disturbing others. You can also use this jack for connecting stereo headphones.

### ● AUX. OUT jack

This jack is used to connect an amplifier or tone cabinet when a more powerful volume is needed for a performance. Also, by connecting it with the line-in jack of a tape deck, you can record music produced by the CNR-80.

## IMPORTANT ADVICE

What to do if.....

### 1) The unit is not activated when the power is turned on. Check the following:

Is the AC plug fully connected to a wall power outlet? Connect it again to make sure. Is power supplied from the outlet? If the outlet is live but the organ does not work, unplug the cord and contact your Yamaha dealer.

### 2) The organ reproduces radio or TV signals.

This can occur if there is a powerful transmitter such as a radio station located in your vicinity. Contact your Yamaha dealer.

### 3) Occasional unpleasant static occurs.

In the majority of such cases, the cause can be traced to the turning on or off of the refrigerators, washing machines, electric pumps or other household appliances. Electrical faults in a nearby outdoor neon sign may also be a cause.

### 4) The CNR-80's sound interferes with radio or TV reception.

A high frequency pulse used for the sound source of the organ may adversely affect TV or radio reception. Therefore, play your organ as far away as possible from TV and radio sets.

### 5) Rattling (sympathetic vibration) occurs.

All materials have critical resonance frequencies at which they vibrate. The organ's continuous tones will naturally cause other objects (windows, objects on shelves, etc) to vibrate.

Change the place of installation whenever such a difficulty occurs.

## LOOKING AFTER YOUR CNR-80

Always treat your organ with the same care you would any fine musical instrument.

The following points are suggested to ensure the best performance of this organ.

- 1) A supply voltage selector is fitted to the CNR-80 in certain markets. Check for the correct power, and also for correct setting of the voltage selector. Consult your Yamaha serviceman regarding any changes.
- 2) Always turn the power OFF after playing.
- 3) Your organ contains no user serviceable components. Refer all service to qualified service technicians only.
- 4) Clean the organ cabinet with a damp cloth containing a neutral cleaning detergent. Use only a soft, dry cloth on the keyboard. Never use paint thinner, alcohol or other chemicals on either the keys or the cabinet.
- 5) The finish on your organ may undergo a chemical reaction if placed in direct contact with polyvinyl products. Do not set vinyl items on the surface or use polyvinyl material to cover the organ for any extended period of time.
- 6) Keep the organ in a location away from direct sunlight, excessive humidity and heat to protect the cabinet finish.
- 7) Do not bump or scratch the cabinet with hard objects.

# Assembly Procedures

# Aufstellungsanleitung

# Instructions de montage

# Manual de Montaje

# Monteringsinstruktioner

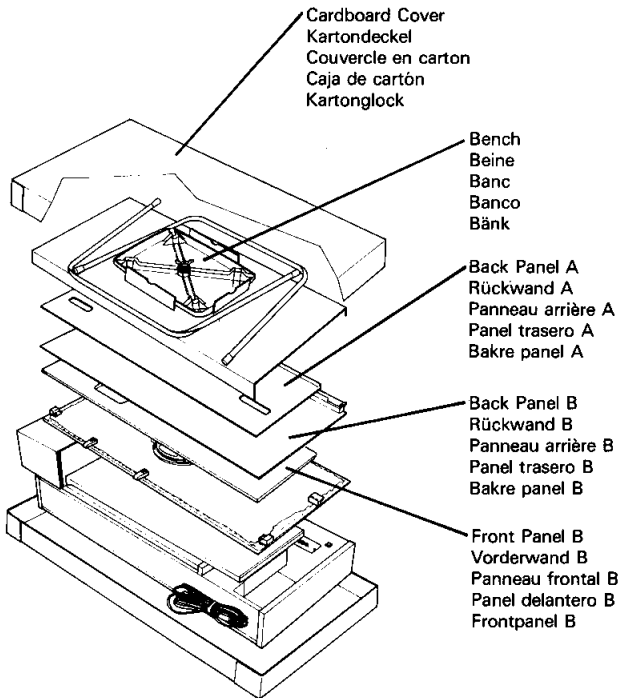

## 1) COMPONENT PARTS

The carton contains the parts shown in the figure below. Before assembling, remove the cardboard cover placed on the top.

## 1) EINZELTEILE

Der Karton enthält die unten abgebildeten Einzelteile. Entfernen Sie zum Auspacken den Deckel.

## 1) PIECES

Le carton l'emballage contient les pièces représentées sur la figure ci-dessous. Avant de procéder à l'assemblage des pièces, retirer le couvercle du carton qui les recouvre.

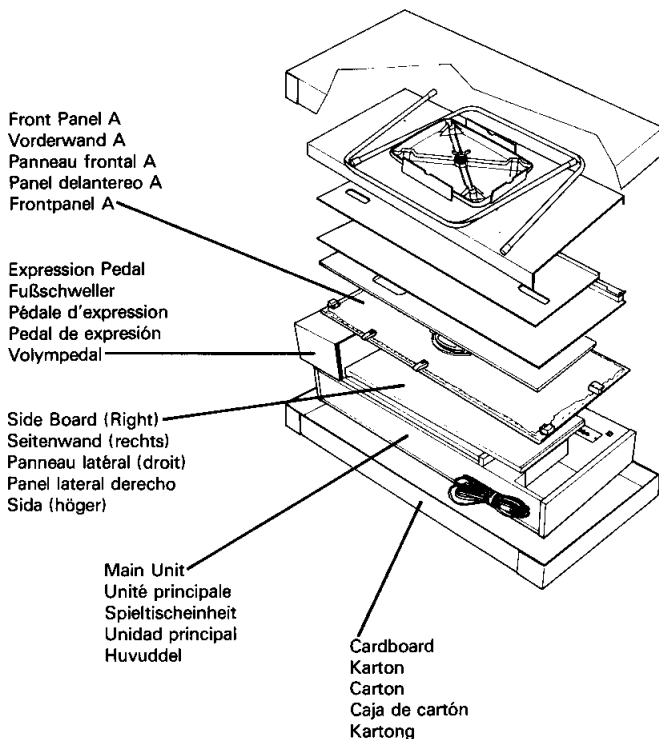

## 1) PIEZAS

La caja de cartón contiene las piezas indicadas en la ilustración siguiente. Antes de armar, quite el cartón corrugado colocado en la parte superior.

## 1) INGÅENDE DELAR

Kartongen innehåller de delar som visas på bilden ovan. Lyft först av kartonglocket före monteringen.

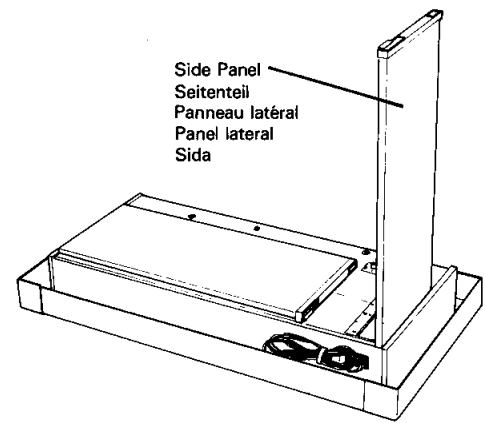
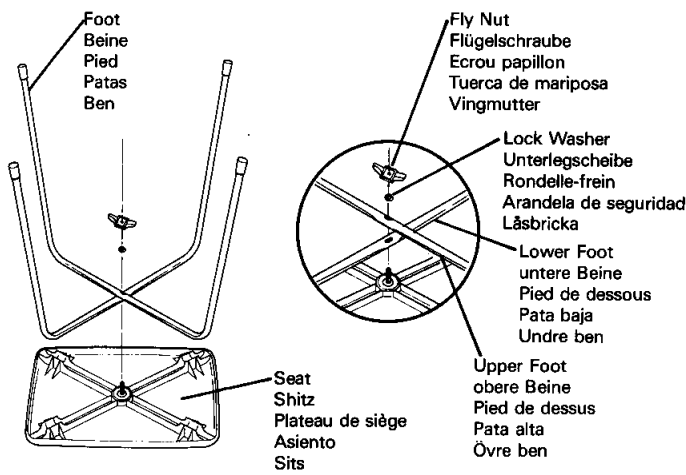

## 2) ASSEMBLING BENCH

Take the parts of Bench (Seat & Foot) off.  
Take Fly Nuts and Lock Washer off.  
Put the two Feet onto Screws of the Seat and then fasten them with Lock Washer and Fly Nut, each in turn.

## 3) ASSEMBLING THE SIDE PANELS

Remove the side panel cover and raise both the right and left side panels.

## 2) ZUSAMMENBAU DER SITZBANK

Nehmen Sie den Sitz und die Beine heraus.  
Lösen Sie die Flügelmutter und entfernen Sie die Unterlegscheibe.  
Setzen Sie die Beine auf die Schraube, legen Sie die Unterlegscheibe darauf und ziehen Sie die Flügelschraube fest.

## 3) MONTAGE DER SEITENWÄNDE

Entfernen Sie die Verpackung der Seitenteile. Richten Sie das rechte und linke Seitenteil auf.

## 2) ASSEMBLAGE DU BANC

Sortir les pièces qui composent le banc (siège et pieds).  
Enlever l'écrou papillon et la rondelle-frein.  
Placer les deux pieds sur les vis du plateau de siège et les fixer alternativement au moyen de leurs rondelles-frein et de leurs écrous papillon respectifs.

## 3) ASSEMBLAGE DES PANNEAUX LATÉRAUX

Prendre les 2 panneaux latéraux et les mettre debout après avoir retiré les caches latéraux.

## 2) MONTAJE DEL BANCO

Desempaque las piezas del banco (asiento y patas).  
Quite la palometa y la arandela de seguridad.  
Coloque las patas en el tornillo del asiento y asegúrelas con la arandela y la palometa.

## 3) MONTAJE DE LOS PANELES LATERALES

Extraiga la cubierta de los paneles laterales y alce ambos paneles.

## 2) MONTERING AV BÄNK

Tag ur delarna till bänken (sits och ben).  
Tag bort vingmuttern och brickan.  
Trä de två benen över skruven och fäst dem med låsbrickan och vingmuttern.

## 3) MONTERING AV SIDOR

Tag bort förpackningen från sidorna och res upp både höger och vänster sidor.

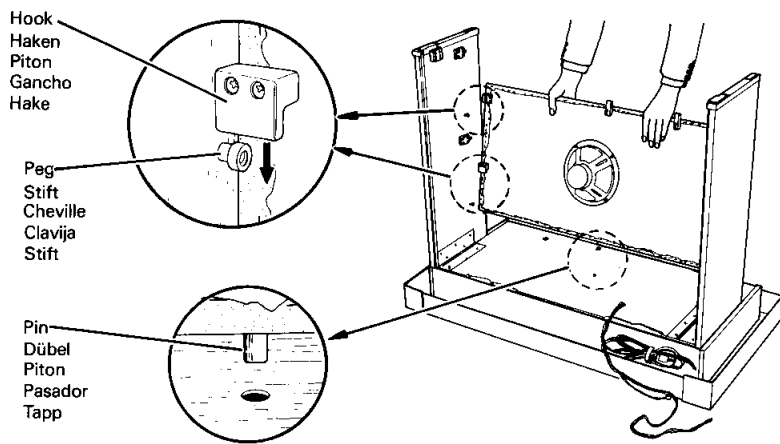

#### 4) ASSEMBLING THE FRONT PANEL [A]

Hook the front panel over the right and left panel pegs, and insert the front-panel pin into the corresponding hole in the shelf panel as shown in the illustration.

Finally, insert the lock unit into the lock block until it is locked firmly.

#### 4) MONTAGE DER LAUTSPRECHERPLATTE [A]

Haken Sie die Lautsprecherplatte über die Stifte am rechten und linken Seitenteil ein und stecken Sie den Zapfen der Lautsprecherplatte wie in der Abbildung gezeigt in das Loch der Spieltischeinheit (Unterseite).

Schieben Sie zum Schluß die Befestigungseinheit in den Befestigungsblock, bis sie fest verbunden ist.

#### 4) ASSEMBLAGE DU PANNEAU FRONTAL [A]

Accrocher le panneau frontal sur les chevilles droite et gauche et insérer le piton du panneau frontal dans la cavité correspondante située sur la tablette, comme indiquée sur le schéma.

Insérer enfin l'unité de verrouillage dans le bloc de verrouillage jusqu'à ce qu'il se bloque convenablement.

#### 4) MONTAJE DEL PANEL DELANTERO [A]

Enganche el panel delantero en las clavijas de los paneles laterales derecho e izquierdo, e inserte el pasador del panel delantero en el orificio correspondiente del estante como se ilustra.

Por último, inserte la unidad de cierre en el bloque hasta cerrarlo seguramente.

#### 4) MONTERING AV FRONTPANEL [A]

Haka frontpanelen över höger och vänster sidostift och passa in tappen i motsvarande hål såsom visas på illustrationen. Se slutligen till att låsen knäpper igen ordentligt.

Montera slutligen låsanordningen i låsblocket. Se till att den fästs ordentligt.

Front Panel B  
Vorderwand B  
Panneau frontal B  
Panel delantero B  
Frontpanel B

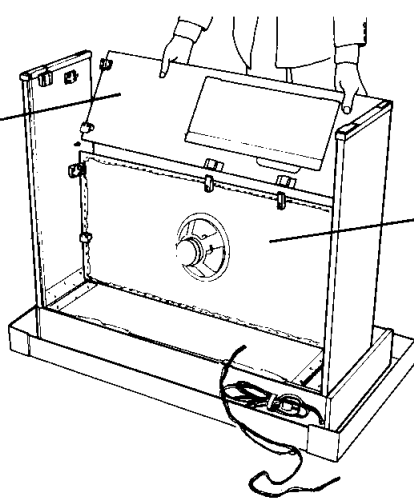

Front Panel A  
Vorderwand A  
Panneau frontal A  
Panel delantero A  
Frontpanel A

### 5) ASSEMBLING THE FRONT PANEL [B]

The hooks on both ends of the Front Panel (B) are aligned with the side pegs. At the same time the two central catches are inserted into the latch on the front panel (A).

Finally, insert the lock unit into the lock block until it is locked firmly.

### 5) MONTAGE DER LAUTSPRECHERPLATTE [B]

Bringen Sie die Schnappverschlüsse an beiden Enden der Lautsprecherplatte mit den Gegenstücken (Seitenteilen) zur Deckung und lassen Sie sie fest einrasten.

Schieben Sie zum Schluß die Befestigungseinheit in den Befestigungsblock, bis sie fest verbunden ist.

### 5) ASSEMBLAGE DU PANNEAU FRONTAL [B]

Les crochets situés aux extrémités du panneau frontal (B) correspondent aux chevilles latérales. De même, les 2 attaches centrales s'insèrent dans le loquet du panneau frontal.

Insérer enfin l'unité de verrouillage dans le bloc de verrouillage jusqu'à ce qu'il se bloque convenablement.

### 5) MONTAJE DEL PANEL DELANTERO [B]

Los ganchos de ambos extremos del panel delantero (B) están alineados con las clavijas laterales. Al mismo tiempo, los dos pestillos centrales se hallan insertados en las hembras de la cerradura del panel delantero (A).

Por último, inserte la unidad de cierre en el bloque hasta cerrarlo seguramente.

### 5) MONTERING AV FRONTPANEL [B]

Hakarna på båda sidor på frontpanel B passas in över stiften. Samtidigt passas de två pinnarna och öglorna på mitten i varandra mot frontpanel A. Se slutligen till att låsen knäpper igen ordentligt.

Montera slutligen låsanordningen i låsblocket. Se till att den fästs ordentligt.

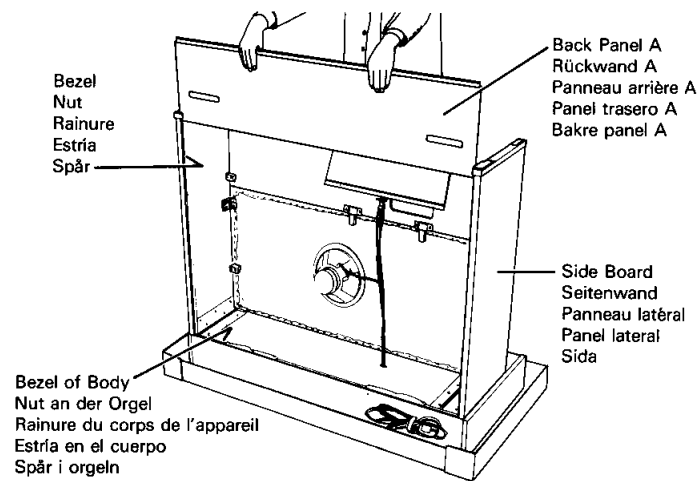
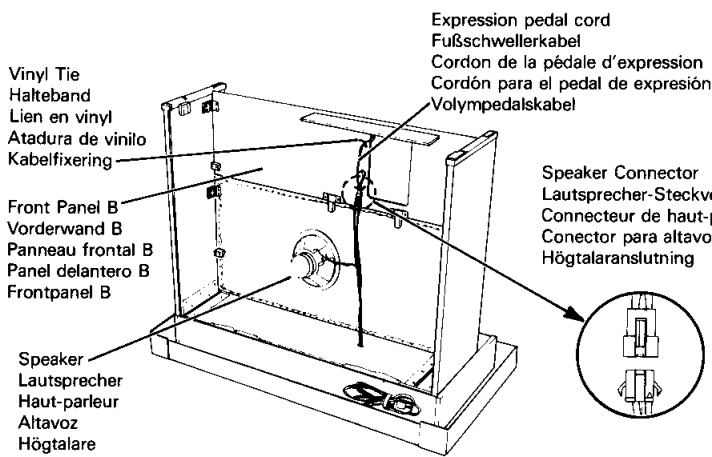

## 6) FIXING CORD

Insert the Speaker Connector as illustrated. Raise the Bottom Panel and fasten the cord with vinyl ties as shown in the illustration.

## 7) ASSEMBLING BACK PANELS

Put Back Panel (A) into the left and right bezel of Side Board and fix it as illustrated.

At this time, check that Back Panel is properly put into the bezel.

## 6) BEFESTIGEN DES KABELS

Schließen Sie die Lautsprecherklemme wie abgebildet an. Heben Sie die Bodenplatte an und befestigen Sie das Kabel mit den Kabelhaltern wie in der Abbildung gezeigt.

Fußschweller-Kabel an den Fußschweller.

## 7) EINSETZEN DER RÜCKWÄNDE

Führen Sie die Rückwand A in die Nut der linken und rechten Seitenwand ein und schieben Sie sie hinein, wie abgebildet. Achten Sie darauf, daß die Rückwand richtig in die Nut an der Orgel eingeführt ist.

## 6) CORDON DE RACCORDEMENT

Insérer le connecteur d'enceintes acoustiques de la manière indiquée sur l'illustration. Soulever le panneau inférieur et serrer le cordon avec des attaches en vinyle de la manière indiquée sur l'illustration.

## 7) MONTAGE DES PANNEAUX ARRIERES

Placer le panneau arrière (A) dans les rainures des panneaux latéraux gauche et droit et le bloquer en place comme illustré. Vérifier alors que le panneau arrière est bien en place dans la rainure du corps de l'appareil.

## 6) CABLE DE FIJACIÓN

Inserte el conector del altavoz de la forma ilustrada. Suba el panel inferior y ate el cable con las amarras de vinilo, como se muestra en la ilustración.

## 7) MONTAJE DE LOS PANELES TRASEROS

Introduzca el panel trasero A en las estrías de los paneles laterales y del cuerpo.

Entonces, compruebe que el panel trasero esté colocado correctamente en la ranura.

## 6) FIXERA KABLAR

Anslut högtalarna enligt illustrationen. Lyft upp bottenplattan och fixera kablarn såsom bilden visar.

## 7) MONTERING AV BAKRE PANELER

Skjut in bakre panel (A) i spårerna på höger och vänster sidor enligt illustrationen. Var noga med att båda sidor går i spåret.

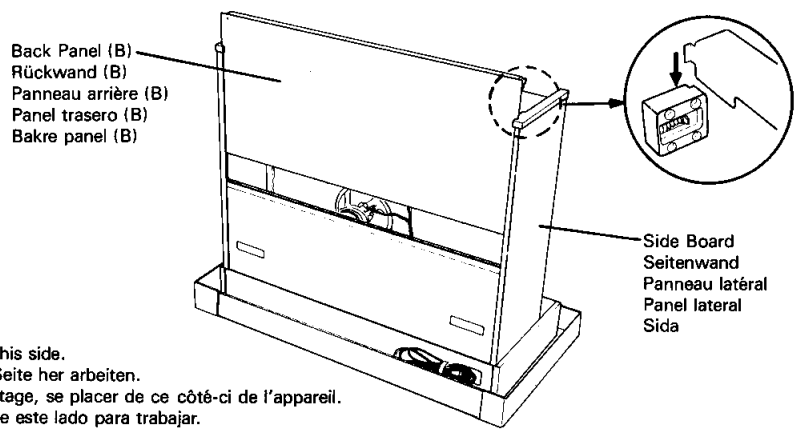

Work from this side.  
 Von dieser Seite her arbeiten.  
 Pour le montage, se placer de ce côté-ci de l'appareil.  
 Colóquese de este lado para trabajar.  
 Arbeta från denna sida.

- ★ Pay attention to both sides of Back Panel.  
 (Mount it so that the uneven side is located inside.)

Put Back Panel (B) into the left and right bezel of Side Board.  
 Insert Back Panel (B) into the bezel of Back Panel (A) and lock it in place with the three retainers on the base.  
 Check whether Back Panel (B) can be drawn up or not.  
 (When it can not be drawn up, that means the locking is perfect.)

- ★ Achten Sie auf die beiden Seiten der Rückwand. (Setzen Sie die Rückwand so ein, daß die rauhe Seite nach innen gerichtet ist.)

Führen Sie die Rückwand B in die Nut der linken und rechten Seitenwand ein.  
 Schieben Sie die Wand hinein, bis sie einrastet, und prüfen Sie, ob sie richtig gesichert ist.  
 (Wenn die Wand nicht wieder herausgezogen werden kann, ist sie richtig befestigt.)

- ★ Attention: regarder les deux faces du panneau arrière, la face qui n'est pas lisse doit se trouver tournée vers l'intérieur.

Placer le panneau arrière (B) dans les rainures des panneaux latéraux gauche et droit.  
 Insérer le panneau arrière (B) dans la rainure du panneau arrière (A) et le bloquer avec les trois retenues du socle.  
 Essayer alors de soulever le panneau arrière (B)  
 (s'il est impossible de le soulever, cela signifie qu'il est bien fixé en place).

- ★ El lado corrugado del panel trasero debe de quedar hacia dentro.

Introduzca el panel trasero B en las ranuras de los paneles laterales.  
 Inserte el panel trasero B en la ranura del panel trasero A y asegúrelo con los tres retenes de la base.  
 Compruebe el correcto enganche del panel trasero B (en este caso el panel no podrá ser deslizado).

- ★ Lägg märke till de bakre panelernas olika yta.  
 (Montera så att den obehandlade sidan kommer inåt.)

Skjut bakre panel (B) i spåren på höger och vänster sidor. Stick bakre panel (B) i spåret på bakre panel (A) och lås det på plats vid de tre punkterna vid basen. Kontrollera om bakre panel (B) kan dras upp eller ej. (Om den inte kan dras upp är monteringen perfekt gjord.)

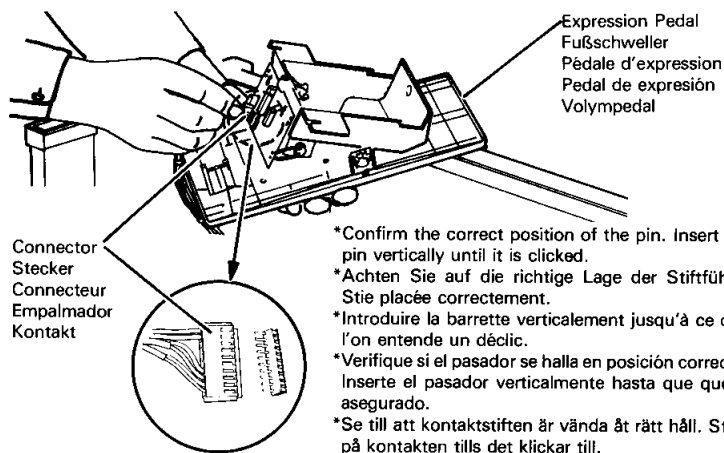
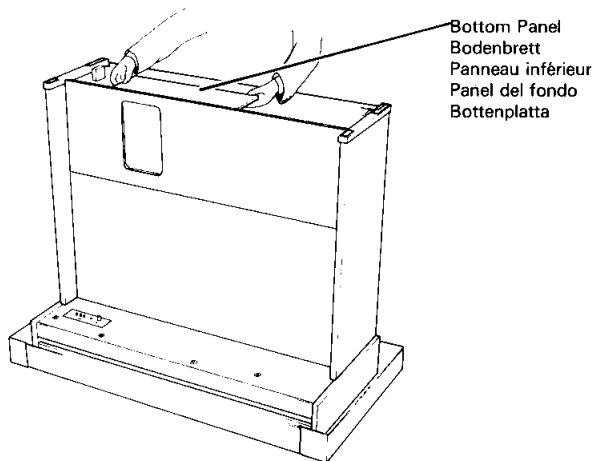

### 8) ASSEMBLING BOTTOM PANEL

Turn over Bottom Panel fixed on Front Panel as illustrated, and lock Back Panel (B) to the fitting.

- ★ After locking, check the locking by pressing Back Panel from upside.

### 9) FIXING CORD FOR WIRING EXPRESSION PEDAL

As illustrated, take off Cord for wiring Expression Pedal which has been fixed in step 6, and connect Expression Pedal Cord to Expression Pedal.

- \* Confirm the correct position of the pin. Insert the pin vertically until it is clicked.
- \* Achten Sie auf die richtige Lage der Stifführer Stie placée correctement.
- \* Introduire la barrette verticalement jusqu'à ce que l'on entende un dé clic.
- \* Verifique si el pasador se halla en posición correcta. Inserte el pasador verticalmente hasta que quede asegurado.
- \* Se till att kontaktstiften är vända åt rätt håll. Stick på kontakten tills det klickar till.

### 8) BEFESTIGEN DES BODENBRETTS

Klappen Sie das an der Vorderwand befestigte Bodenbrett auf und befestigen Sie es an der Rückwand B, wie gezeigt.

- ★ Prüfen Sie die richtige Befestigung des Bodenbretts durch leichten Druck von oben.

### 9) ANSCHLIESSEN DES FUSSSCHWELLERKABELS

Nehmen Sie den Stecker des im Schritt 6 befestigten Fußschwellerkabels und schließen Sie ihn an das Lautstärkepedal an, wie abgebildet.

### 8) MONTAGE DU PANNEAU INFÉRIEUR

Relever le panneau inférieur qui se trouve attaché au panneau avant, comme illustré, et le mettre dans les butées de fixation sur le panneau arrière (B).

- ★ Vérifier le verrouillage en appuyant sur le dessus du panneau arrière.

### 9) BRANCHEMENT DU CORDON DE LA PÉDALE D'EXPRESSION

Comme illustré, faire sortir l'extrémité du cordon de la pédale d'expression (mis en place à l'étape 6) par l'orifice du panneau avant, puis brancher le cordon de la pédale d'expression à la pédale d'expression.

### 8) MONTAJE DEL PANEL INFERIOR

Levante el panel del fondo que se encuentra montado sobre el panel delantero y asegúrelo al panel trasero por medio de los ganchos.

- ★ Haga presión sobre la superficie superior del panel del fondo para comprobar su montaje correcto.

### 9) INSTALACION DEL CABLE DEL PEDAL DE VOLUMEN GLOBAL

Quite el cable, el cual se fijó al panel delantero en el paso 6, y conéctelo al pedal como se muestra en la ilustración.

### 8) MONTERING AV BOTTENPLATTA

Fäll upp bottenplattan som är fäst vid frontpanelen enligt bilden, och lås bakre panelen (B) i fästet.

- ★ Efter låsningen, kontrollera denna genom att trycka ner den bakre panelen från ovasidan.

### 9) ANSLUTNING AV KABEL TILL VOLYMPEDAL

Tag, såsom visas i illustrationen, kabeln för volympedalen som fixerades i Steg 6 och anslut den till volympedalen.



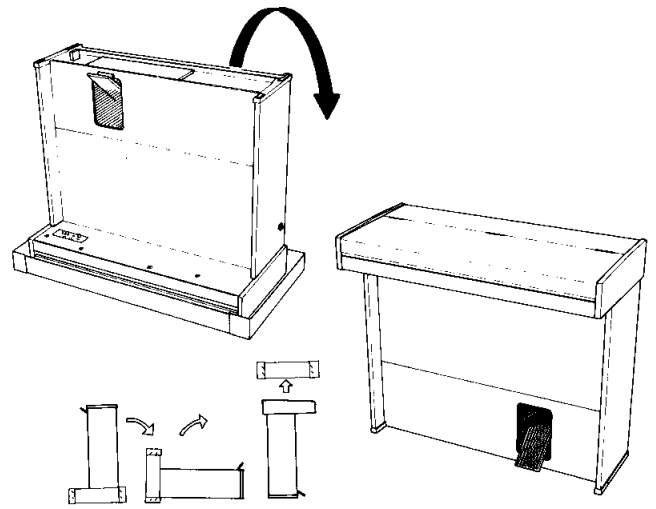
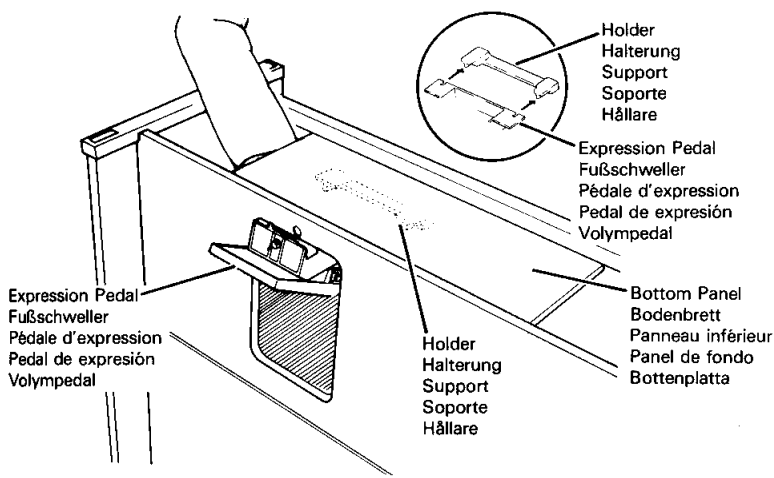

### 10) MOUNTING EXPRESSION PEDAL

Insert Expression Pedal through Expression Pedal Window on Front Panel.

Put Expression Pedal into Holder fixed on Bottom Panel.

- ★ Connection of cord must be done without tangling the cord.

### 11) COMPLETION DIAGRAM

After completing the assembly, set up the organ as shown in the figure below.

Hold the lid and lift it up in the direction of the arrow.

### 10) EINBAU DES FUßSCHWELLERS

Setzen Sie den Fußschweller in die Öffnung der Vorderwand. Führen Sie den Fußschweller in die Halterung, welche am Bodenbrett befestigt ist.

Befestigen Sie den Fußschweller mit der Flügelschraube, wie abgebildet.

- ★ Achten Sie darauf, daß das Lautstärkepedalkabel nicht eingeklemmt ist.

### 11) ENDGÜLTIGE AUFSTELLUNG

Stellen Sie nach dem Zusammenbau die Orgel auf, wie gezeigt. Den Deckel halten und in Pfeilrichtung anheben.

### 10) MONTAGE DE LA PEDALE D'EXPRESSION

Introduire la pédale d'expression dans l'orifice prévu pour elle sur le panneau avant.

Placer la pédale d'expression dans le support situé sur le panneau inférieur.

- ★ Faire attention que le cordon ne soit pas torsadé.

### 11) SCHEMA DE L'ASSEMBLAGE TERMINE

Après avoir terminé l'assemblage, mettre l'appareil sur ses pieds comme illustré ci-dessous.

Tenir le couvercle et le soulever en direction de la flèche.

### 10) MONTAJE DEL PEDAL DE VOLUMEN GLOBAL

Pase el pedal a través de la ventanilla del panel delantero.

Monte el pedal en el soporte fijado al panel del fondo.

Asegure el pedal con la tuerca de palometa como se ilustra.

- ★ Evite enredar el cable al hacer su conexión.

### 11) DIAGRAMA DEL PRODUCTO ACABADO

Después de armar por completo, ponga a la vista el órgano principal como se indica en la ilustración de arriba.

Sostenga y levante la tapa en el sentido de la flecha.

### 10) MONTERING AV VOLYMPEDAL

Sätt in volympedalen i det hål som finns på frontpanelen. Skjut in pedalen i den hållare som finns fäst på bottenplattan.

- ★ Kabelanslutningarna måste göras utan att kablarna trasslar sig.

### 11) AVSLUTNING AV MONTERING

Efter att ha avslutat sammansättningen, vänd orgeln rätt såsom visas på bilden.

Håll i locket och lyft i pilens riktning.

Set Point (Setting by — Driver)  
 Einstellung (mit einem Schraubenzieher)  
 Repère de réglage (Régler avec un tournevis)  
 Marca de ajuste (Gire con un destornillador)  
 Omställning (med skruvmejsel)

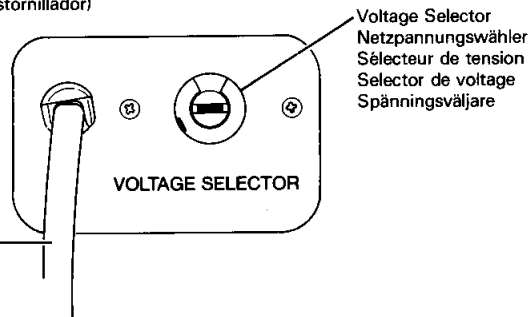

Power Supply Cord  
 Netzkabel  
 Cordon d'alimentation  
 Cordón de alimentación  
 Nätkabel

## 12) VOLTAGE SELECTOR

In certain markets the CNR-80 is fitted with a supply voltage selector. If a voltage selector is fitted to your CNR-80, please adjust it to correspond with your supply voltage as follows:  
 Before plugging the power cord, check that the Voltage Selector is set to the proper position.

- ★ If you move to an area where the power supply voltage is different, be sure to reset the Voltage Selector to the correct position for the voltage in that area. Please check with the nearest Yamaha dealer for details.
- ★ If no voltage selector has been fitted, the operating voltage of your CNR-80 has been preset to the supply voltage in your area. Just make sure that you connect your plug properly to your AC supply outlet.

## 12) NETZSPANNUNGSWÄHLER

In einigen Ländern wird die CNR-80 mit einem Netzspannungswähler geliefert. Falls bei Ihrer CNR-80 ein Netzspannungswähler vorhanden ist, muß er auf die richtige Netzspannung eingestellt werden.  
 Prüfen Sie die Stellung des Netzspannungswählers vor dem Einstecken des Netzkabels.

- ★ Falls Sie die Orgel an einem Ort mit anderer Netzspannung betreiben wollen, müssen Sie den Netzspannungswähler für die neue Spannung umstellen; gleichzeitig muß die Sicherung ausgetauscht werden. Lassen Sie sich bei auftretenden Fragen von Ihrem YAMAHA-Fachhändler beraten.
- ★ Falls Ihre CNR-80 keinen Netzspannungswähler besitzt, ist die richtige Netzspannung bereits eingestellt. Schließen Sie einfach das Netzkabel an eine Steckdose an.

## 12) SELECTEUR DE TENSION

Pour la vente dans certains pays, le modèle CNR-80 est équipé d'un sélecteur de tension. Si c'est le cas pour votre appareil, procédez si nécessaire au réglage de la tension de la manière suivante.  
 Avant de brancher le cordon d'alimentation, vérifiez que le sélecteur de tension est correctement réglé.

- ★ Si vous emménagez dans une région où la tension est différente, assurez-vous de placer le sélecteur de tension sur la position correspondant à la nouvelle tension. Pour plus de détails, consultez votre revendeur Yamaha.
- ★ S'il n'y a pas de sélecteur de tension, la tension de votre CNR-80 a été réglée sur la tension de votre région. Il suffit de le brancher correctement sur une prise secteur.

## 12) SELECTOR DE VOLTAJE

En determinados países, el órgano viene con un selector de voltaje. Si su órgano tiene un selector de voltaje, ajústelo de acuerdo con la tensión local si es necesario. Hágalo del modo siguiente:  
 Antes de enchufar el cordón de alimentación inspeccione el Selector de Voltaje.

- ★ Si se traslada Ud. a una zona en que sea diferente el voltaje, cerciórese de reajustar el Selector de Voltaje en la posición correcta para el nuevo voltaje. Al mismo tiempo, quizás sea necesario cambiar el fusible. Para detalles, consulte al agente de Yamaha más cercano.
- ★ Si el órgano no tiene selector de voltaje es porque has sido ajustado en fábrica de acuerdo con el voltaje local. Basta con asegurarse de enchufarlo correctamente en una toma de corriente.

## 12) SPÄNNINGSVÄLJARE

I en del länder är CNR-80 utrustad med en spänningsväljare. Om en sådan finns på Din CNR-80 var vänlig och justera den till den spänning Du har enligt följande:  
 Innan Du sätter nätkabeln i väggkontakten vrider Du spänningsväljaren till rätt läge.

- ★ Om Du flyttar till annan plats där spänningen kan vara annorlunda måste Du försäkra Dig om att omkopplaren också ställs in i rätt läge. Kontakta gärna närmaste Yamaha handlare för detaljer.
- ★ Om det inte finns någon spänningsomkopplare på Din CNR-80 är instrumentet avpassat för den spänning som gäller i Ditt område. Försäkra Dig bara om att Du ansluter till ett felfritt vägguttag.

# Specifications / Technische Daten / Caractéristiques Techniques / Especificaciones / Specifikationer

## KEYBOARD

61 keys (C1-C6)

## VOICE SELECTORS

Pipe Organ/Flute  
Jazz Organ/Trumpet  
Piano/Trombone  
Harpsichord/Clarinet  
Vibraphone/Violin  
■/ ▣ Selector

## EFFECTS

Sustain  
Vibrato Depth

## RHYTHM

March/Disco  
Waltz/Rock  
Tango/Swing  
Rhumba/Samba  
Bossa-nova/16 Beat  
■/ ▣ Selector  
Synchro Start  
Start  
Auto Fill In  
Volume  
Tempo  
Tempo Lamp

## AUTO BASS CHORD

Single Finger Chord  
Fingered Chord  
Memory  
Volume

## ARPEGGIO

Volume

## MAIN CONTROLS

Master Volume  
Expression Pedal  
Power Switch  
Pilot Lamp

## OTHER FITTINGS

Headphones Jack  
Aux. Out Jack  
Voltage Selector

## MAIN AMPLIFIER

15W (8Ω)

## SPEAKER

20cm (8") (8Ω)

## CIRCUITRY

Solid State (incl. LSIs and ICs)  
Power Consumption : See organ nameplate  
Power Source : 50/60 Hz AC

## DIMENSIONS

93.6 (W) × 41.0 (D) × 81.1 (H) cm  
(36-3/4" × 16" × 32")

## WEIGHT

34kg (75 lbs.)

## FINISH

American Walnut Grain

\*Specifications subject to change without notice.  
\*Anderungen ohne Vorankündigung vorbehalten.  
\*Sous toute réserve modification des caractéristiques sans préavis.  
\*Especificaciones sujetas a cambio sin previo aviso.  
\*Rätt till ändringar utan föregående meddelande förbehålles.

SINCE 1887



**YAMAHA**

NIPPON GAKKI CO., LTD. HAMAMATSU, JAPAN