

# YAMAHA AX-330e

*Natural Sound Stereo Integrated Amplifier*

*30W + 30W (8Ω) RMS Output Power, 0.05% THD, 20-20,000 Hz*

*MAIN DIRECT for High Quality Sound*

*Increased Low Impedance Drivability*

OWNER'S MANUAL

## CONTENTS

PRECAUTIONS .....	2
CONNECTION DIAGRAM .....	3
CONNECTIONS.....	4
CONTROLS AND THEIR FUNCTIONS.....	5
OPERATIONS .....	6
TROUBLESHOOTING .....	6
SPECIFICATIONS .....	7

Thank you for purchasing the YAMAHA Integrated Amplifier. In order to ensure proper operation for the best possible performance, please read this manual thoroughly before connecting up your new amplifier and turning it on.

**IMPORTANT!**

Please record the serial number of your unit in the space below.

Serial No:

**PRECAUTIONS**

**OWNER'S MANUAL**

Keep this manual in a safe place for future reference.

**LOCATION**

Avoid placing your unit in direct sunlight or close to a source of heat. Also avoid locations in which the device is likely to be subjected to excessive dust, cold or moisture.

**VENTILATION**

The openings on the cabinet ensure the ventilation of the amplifier. If these openings are obstructed, the temperature inside the cabinet will rise rapidly and eventually damage the circuits. Therefore, avoid placing objects against these openings and do not install your amplifier in a place such that the flow of air through the ventilation openings could be impeded.

**HANDLING**

● Power cord

When removing the power plug from the wall outlet, always pull directly on the plug. Never yank the cord as this may result in damage to the cord and possibly a short-circuit.

If you do not intend to use this unit for an extended period of time, it is advisable to unplug the power cord.

● Switches and knobs

Avoid applying excessive force to the switches and knobs.

● Relocation

Before moving your amplifier, be sure to unplug the power cord and remove all other connecting cables.

**IN CASE OF TROUBLE**

● Troubleshooting Chart

Consult the Troubleshooting Chart for advice on the common operation errors before concluding that your amplifier is faulty.

● Servicing

Do not open the cabinet or attempt to make repairs by yourself, as this may aggravate the damage and expose you to an electrical shock.

● Object and liquid entry

See to it that foreign objects or spilled liquids do not enter inside the cabinet. Should this case arise, consult your YAMAHA dealer.

**CLEANING**

Wipe off dust with a dry soft cloth. To remove dirt or fingermarks, use a soft damp cloth then dry immediately with a clean cloth. Do not use alcohol, thinners or other chemical solvents since they may damage the finish or remove the panel lettering.

Do not use any aerosol sprays near this unit as these products can easily get into the unit and damage the circuitry.

**SPECIAL INSTRUCTIONS FOR THE BRITISH MODEL**

THE WIRES IN THE MAINS LEAD ARE COLOURED IN ACCORDANCE WITH THE FOLLOWING CODE:

Blue: NEUTRAL

Brown: LIVE

As the colours of the wires in the mains lead of this apparatus may not correspond with the coloured markings identifying the terminals in your plug, proceed as follows:

The wire which is coloured BLUE must be connected to the terminal which is marked with the letter N or coloured BLACK. The wire which is coloured BROWN must be connected to the terminal which is marked with the letter L or coloured RED.

# CONNECTION DIAGRAM

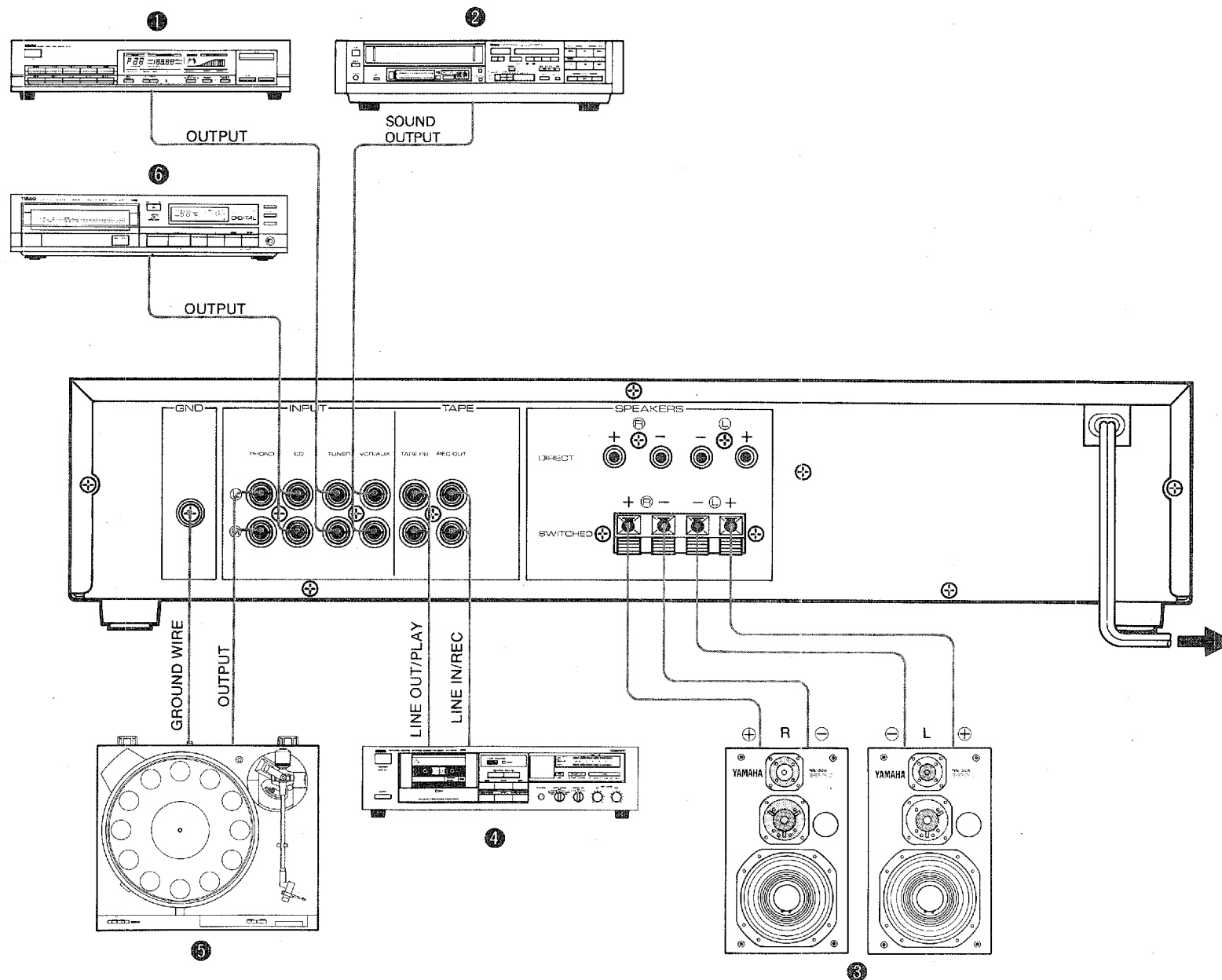

## CONNECTIONS

The connection diagram is provided on page 3.

- ① Tuner
- ② Video player
- ③ Speakers
- ④ Tape deck
- ⑤ Turntable
- ⑥ Compact disc player

*Before making any connections turn off all equipment.*

*Be sure to connect the left (L) and right (R) channels consistently between components.*

### ● CONNECTING THE SPEAKERS

To listen through headphones, use SWITCHED SPEAKERS terminals. No sound will be emitted from the speakers if headphones are connected to the unit.

To listen directly from the speakers, use DIRECT SPEAKERS terminals. Sound signals will then be output as pure, more direct sounds, without passing through the headphones output circuit.

Note that both terminals should never be used at the same time, because to do so might result in a malfunction.

Connect the cords for the left speakers to the L terminals and the right speaker cords to the R terminals, ensuring that the polarity (+ and -) markings are observed. If the polarity is reversed at either speaker the sound will be unnatural and lack bass. Speaker cords should be cut as short as possible. Avoid coiling the wire on the floor or bundling it up with cords from other system components.

### When connecting to SWITCHED SPEAKERS terminals

Strip off about 10 mm (3/8 in) of the insulation (leaving only the core wire) from the end of each speaker connection wire to be connected to this unit. Press the lever below one of the SPEAKER connection terminals and insert this exposed core wire into the hole, as shown in the illustration. When the lever is then released, the cord is locked in securely.

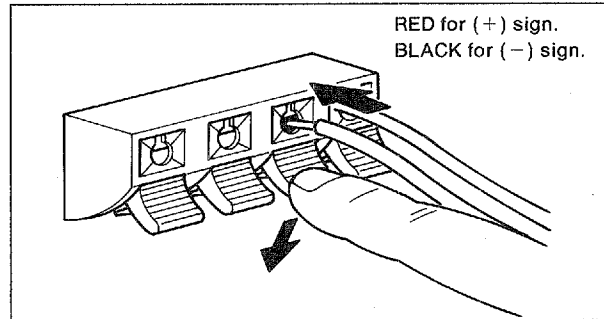

### When connecting to DIRECT SPEAKERS terminals

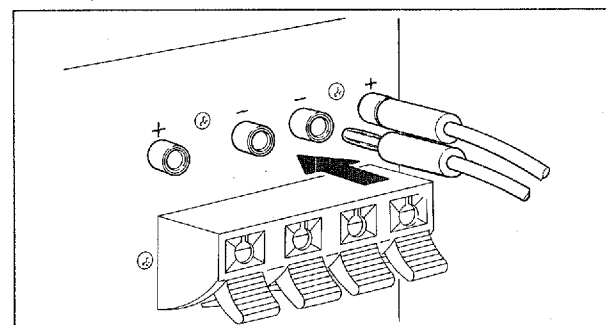

### ● CONNECTING A TURNTABLE

Connect the output cords of the turntable to the amplifier Phono jacks and connect the ground wire to the GND terminal. Normally connecting the ground wire produces minimum hum but in some cases better results are obtained with the ground wire disconnected. The turntable component and its output cords should be positioned well away from sources of hum such as power cords or power transformers of other system components.

### ● CONNECTING A TUNER

Connect the cords from the Tuner's output jacks to the TUNER jacks of the amplifier. As the amplifier power supply may generate a certain amount of radio frequency noise, position the tuner so that its AM antenna is well away from the amplifier.

● **CONNECTING TO THE CD AND VCR/AUX JACK**  
Connect your CD component to the CD terminals as video sound output leads the VCR/AUX terminals. Please note that a turntable cannot be connected to these jacks as they do not provide the necessary RIAA equalization.

### ● CONNECTING THE TAPE DECK

Connect the tape deck's Line In jacks to the amplifier's Rec Out jacks, ensuring that left and right are not reversed. Then connect the tape deck's Lir Out jacks to the amplifier's Tape PB jacks.

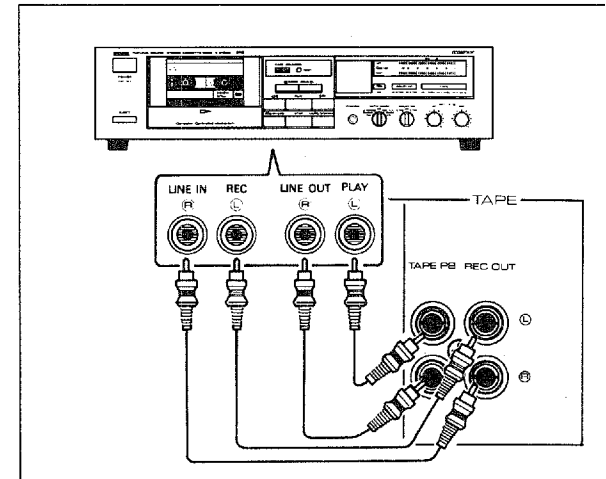

## CONTROLS AND THEIR FUNCTIONS

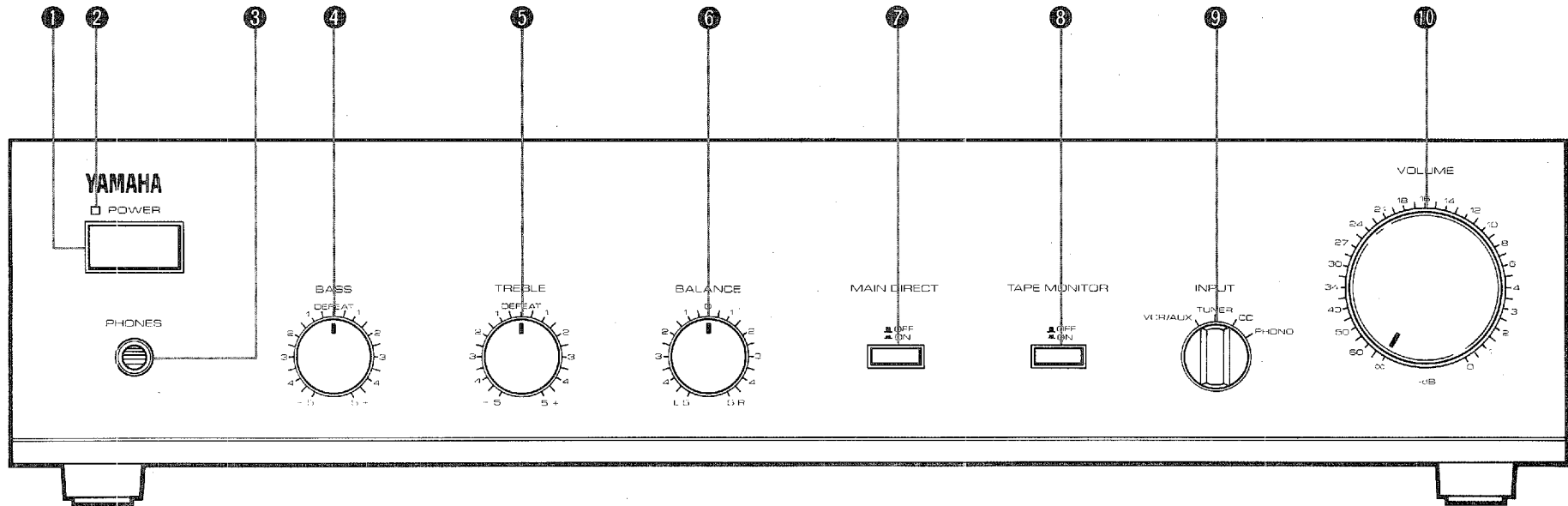

### ❶ POWER SWITCH (POWER)

Press once to turn the power ON and once again to turn the power OFF. Before turning the power ON set the volume to its lowest position (extreme counterclockwise), to protect the speakers from any sudden high level sound.

### ❷ POWER ON INDICATOR

Illuminated when power is ON.

### ❸ HEADPHONES JACK (PHONES)

Stereo headphones with a standard plug can be connected to this jack.

### ❹ BASS CONTROL KNOB (BASS)

This knob controls bass response. Turn it clockwise to boost or counterclockwise to attenuate bass response. When this knob is in the center defeat position a flat response is obtained.

### ❺ TREBLE CONTROL KNOB (TREBLE)

This knob controls treble response. Turn it clockwise to boost or counterclockwise to attenuate treble response. When this knob is in the center defeat position a flat response is obtained.

### ❻ BALANCE CONTROL KNOB (BALANCE)

This knob is used to adjust the relative volume of the left and right channels, enabling you to compensate for unbalance created by installation locations of the speakers.

### ❼ MAIN DIRECT SWITCH (MAIN DIRECT)

Pressing this switch routes the audio input signal directly to this unit output stage, bypassing the tone controls and balance control circuits for the purest possible sound. Remember that none of the controls just mentioned will have any effect when MAIN DIRECT is pressed.

### ❸ TAPE MONITOR SWITCH (TAPE MONITOR)

Press this button to monitor the sound from a tape deck connected to the Tape PB jacks on the rear panel.

### ❹ INPUT SELECTOR

Selects the program source you wish to listen to.

### ❺ VOLUME CONTROL KNOB (VOLUME)

This controls the sound level. Turning clockwise increases the sound volume and turning counterclockwise decreases it. Set this knob to the minimum level before turning the power ON or using the Inp Selector to select a different sound source, therefore, protecting the speakers from any sudden high level sound.

## OPERATIONS

### ● Normal listening operation

1. Turn the volume control to the minimum level before turning the power ON. The power indicator is illuminated.
2. Select the desired program source using the INPUT SELECTOR.
3. Activate your chosen component.
4. Adjust your VOLUME, BASS, TREBLE and BALANCE to provide the desired sound quality.

### ● To record from a program source

1. Turn the volume control to the minimum setting then press the power switch (to the ON position). The power indicator lights up.
2. Select the desired program source using the INPUT SELECTOR. Ensure the Tape Monitor is OFF.
3. Activate the source program component.
4. Advance the volume control to a suitable level.
5. Commence recording by activating the tape deck connected to the Tape jacks.
6. The recording can be monitored through the speakers or headphones. If the tape deck has 3 head monitoring capability the just recorded signal can be monitored by depressing the Tape Monitor switch.

## TROUBLESHOOTING

Before assuming that your unit is faulty, please check the following troubleshooting list which details the corrective action you can take yourself without having to call a service engineer. If you have any doubts or questions, contact your nearest Yamaha dealer.

PROBLEM	CAUSE	REMEDY
Power is not supplied even though the Power switch is turned on .	The power plug is not securely plugged in.	Plug it in securely.
There is no sound with any input selector switches pressed.	The Speakers switch is not set correctly.	Set the Speakers switch correctly.
	The input cords are not connected securely.	Connect them securely.
	The speaker system is not connected correctly.	Check and secure connections.
	The Tape Monitor is ON.	Push the Tape Monitor switch to the OFF position.
There is no sound from one speaker.	The speaker connections are not secure.	Secure the connections.
	The Balance control is set all the way to the left or right.	Adjust the Balance control correctly.
There is a lack of bass and no ambience.	The + and - cords have been reversed at the amp or speakers.	Connect the speaker wires in the correct phase (+ and -).
There is a humming sound when playing records.	The input cords are not connected securely.	Plug the input cords in securely.
	The turntable's ground wire is not connected.	Connect the ground wire.
There is a howling sound when playing records at high volume.	The turntable and the speakers are too close together or the turntable is not mounted on a firm surface.	Change the location of the turntable or the speakers.
The sound suddenly goes off.	Driving speakers outside the rated impedance range at high power for an extended period has activated the speaker protection circuit.	Turning this unit off and then on will reset the speaker protection circuit. Use speakers inside the rated impedance range.
	There is a malfunction in the amplifier.	Consult your Yamaha dealer.

## SPECIFICATIONS

<b>Minimum RMS Output Power Per Channel</b>	
20Hz ~ 20kHz 0.05% THD 8Ω .....	30W
<b>Dynamic Power</b>	
1kHz 1% THD 8/4/2 Ω .....	55W/75W/80W
<b>Power Bandwidth</b>	
0.05% THD 15W 8Ω .....	10Hz ~ 50kHz
<b>Damping Factor</b>	
1kHz 8Ω .....	40
<b>Input Sensitivity (New IHF)</b>	
Phono MM .....	0.47mV
VCR·AUX/TAPE/TUNER/CD .....	28mV
<b>Maximum Input Signal</b>	
0.02% THD 1kHz Phono MM .....	150mV
<b>Output Level/Impedance</b>	
REC OUT .....	150mV/560Ω
<b>Headphone Jack Rated Output</b>	
0.05% THD 8Ω .....	0.5V/220Ω
<b>Frequency Response (VCR·AUX/TAPE/TUNER/CD)</b>	
20Hz ~ 20kHz .....	+ 0/ - 0.5dB
<b>RIAA Equalization Deviation</b>	
Phono MM RIAA .....	± 0.5dB
<b>Total Harmonic Distortion (20Hz ~ 20kHz)</b>	
Phono MM to REC OUT 3V .....	0.01%
VCR·AUX/TAPE/TUNER/CD to SP OUT 15W/8Ω .....	0.01%
<b>Intermodulation Distortion (VCR·AUX/TAPE/TUNER/CD)</b>	
Rated Output/8Ω .....	0.05%
<b>Signal to Noise Ratio (IHF-A-Network)</b>	
Phono MM (5mV Input Shorted) .....	88dB
VCR·AUX/TAPE/TUNER/CD (Shorted) .....	100dB
<b>Signal to Noise Ratio (New IHF)</b>	
Phono MM .....	74dB
VCR·AUX/TAPE/TUNER/CD .....	85dB
<b>Residual Noise (IHF-A-Network)</b> .....	160μV

<b>Channel Separation (Vol - 30dB)</b>	
Phono MM (Input Shorted 1kHz/10kHz) .....	60dB/40dB
VCR·AUX/TAPE/TUNER/CD (Input 5.1kΩ Terminated 1kHz/10kHz) .....	60dB/40dB
<b>Tone Control Characteristics</b>	
BASS boost/cut .....	± 10dB (at 20Hz)
BASS turnover frequency .....	350Hz
TREBLE boost/cut .....	± 10dB (at 20Hz)
TREBLE turnover frequency .....	3.5kHz
<b>Gain Tracking Error (0 ~ - 60dB)</b> .....	3dB
<b>Power Supply</b>	
British and Australian models .....	AC240V 50Hz
<b>Power Consumption</b>	
British and Australian models .....	100W
<b>Dimensions (W x H x D)</b> .....	435 x 98 x 251mm (17-1/8" x 3-7/8" x 9-7/8")
<b>Weight</b> .....	4.4kg (9lbs. 11oz.)

\* Specifications subject to change without notice.

# YAMAHA

---

**YAMAHA ELECTRONICS CORPORATION, USA** 6660 ORANGETHORPE AVE., BUENA PARK, CALIF. 90620, U.S.A.  
**YAMAHA CANADA MUSIC LTD.** 135 MILNER AVE., SCARBOROUGH, ONTARIO M1S 3R1, CANADA  
**YAMAHA ELECTRONIK EUROPA G.m.b.H.** 2084 RELLINGEN, BEI HAMBURG, SIEMENSSTR. 22/34, F.R. OF GERMANY  
**YAMAHA ELECTRONIQUE FRANCE S.A.** 17 RUE DES CAMPANULES, LOGNES 77321 MARNE LA VALLEE CEDEX 2, FRANCE  
**YAMAHA ELECTRONICS (UK) LTD.** YAMAHA HOUSE, 200 RICKMANSWORTH ROAD WATFORD, HERTS WD1 7JS, ENGLAND  
**YAMAHA SCANDINAVIA A.B.** J A WETTERGRENS GATA 1, BOX 30053, 400 43 VÄSTRA FRÖLUNDA, SWEDEN  
**YAMAHA MUSIC AUSTRALIA PTY, LTD.** 17-33 MARKET ST., SOUTH MELBOURNE, 3205 VIC., AUSTRALIA

**YAMAHA CORPORATION**  
10-1 NAKAZAWA-CHO, HAMAMATSU, JAPAN  
VH10360-0 Printed in Japan BWG/G