



木製リコーダー / 取扱説明書

Wooden Recorder / Owner's Manual

Holzblockflöte / Bedienungsanleitung

Flûte à bec en bois / Manuel d'utilisation

Flauta dulce de madera / Manual de instrucciones

Flauta Doce de Madeira / Manual do Proprietário

Деревянная блок-флейта / Руководство пользователя

木制竖笛 / 使用手册

목제 리코더 / 사용설명서

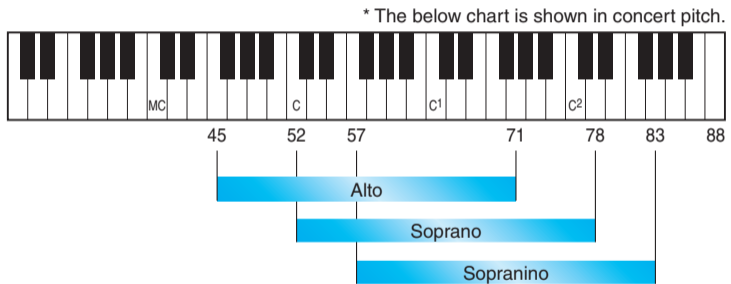
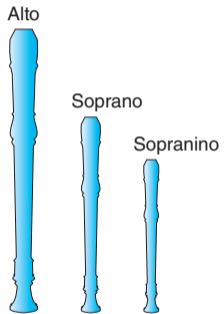

## **Congratulations!**

You are now the owner of a high quality musical instrument. Thank you for choosing Yamaha.

For instructions on the proper assembly of the instrument and how to keep the instrument in optimal condition for as long as possible, we urge you to read this Owner's Manual thoroughly.

## **Using the instrument**

1. When assembling the instrument, apply a small amount of the supplied cork grease to the cork on the ends of the joint sections.
2. Before playing the instrument warm the entire instrument in your hands. The headjoint should be warmed to body temperature.  
Playing a cold instrument can result in condensation or cracking. Be especially careful during the winter months to keep the instrument at or near room temperature.
3. New instruments need to be broken-in and should be played only a short time at first to prevent the wood body from cracking.  
Playing time can be gradually increased but for the first two weeks it should not exceed 10 minutes per day.
4. After every use, wrap a piece of gauze around the end of the supplied cleaning rod. Carefully wipe out the moisture from inside the instrument.  
Be careful not to damage the labium (lip) and surrounding area as they play an important role in the instrument's sound production.  
To prevent the instrument's surface from deformation or damage, never use thinners or benzene.
5. Recorders are weak against sudden changes in temperature or humidity. Avoid direct sunlight, exposure to heaters and other such heat sources, and high humidity.
6. Please take note that modifying or altering the instrument may void the warranty.

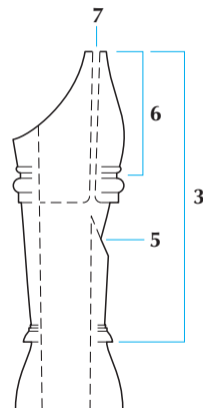
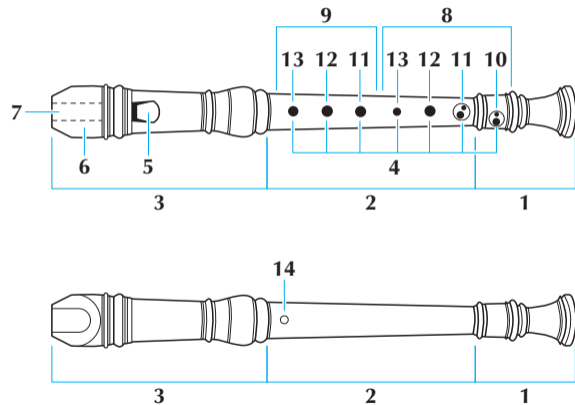

## 각부의 명칭

1	足部管 (フットジョイント) そくぶかん	Footjoint	Fußstück	Pied	Sección inferior	Pé	Нижнее колено	笛尾	아랫관
2	中部管 (ミドルジョイント) ちゅうぶかん	Middle joint	Mittelstück	Corps	Sección central	Corpo	Основная часть	笛身	가운데관
3	頭部管 (ヘッドジョイント) とうぶかん	Headjoint	Kopfstück	Embouchure	Sección superior	Cabeça	Головка флейты	笛头	윗관
4	音孔 (トーンホール) おんこう	Toneholes	Tonlöcher	Cheminées	Agujeros	Furos	Тоновые отверстия	音孔	음공
5	窓 (ラビューム) まど	Labium (Lip)	Labium	Biseau	Labio	Janela	Рассекатель	发音口	라비움 (입술)
6	唄口 (ベック) うたぐち	Mouthpiece	Mundstück	Bec	Boquilla	Bocal	Мундштук	吹嘴	취구
7	ウィンドウェイ	Windway	Luftdurchgang	Canal	Entrade del aire	Canal de entrada de ar	Воздуховод	吹气口	기도
8	右手 みぎて	Right hand	Rechte Hand	Main droite	Mano derecha	Mão direita	Правая рука	右手	오른손
9	左手 ひだりて	Left hand	Linke Hand	Main gauche	Mano izquierda	Mão esquerda	Левая рука	左手	왼손
10	小指 こゆび	Little finger	Kleiner Finger	Auriculaire	Meñique	Dedo mínimo	Мизинец	小指	새끼손가락
11	くすり指 ゆび	Ring finger	Ringfinger	Annulaire	Anular	Dedo anelar	Безымянный палец	无名指	약지
12	中指 なかゆび	Middle finger	Mittelfinger	Majeur	Medio	Dedo médio	Средний палец	中指	중지
13	人さし指 ひとゆび	Index finger	Zeigefinger	Index	Indice	Indicador	Указательный палец	食指	검지
14	親指 おやゆび	Thumb	Daumen	Pouce	Pulgar	Polegar	Большой палец	大拇指	엄지

運指表 / Fingering Chart / Griffabelle / Tablature / Gráfico de digitación / Diagrama dos dedilhados / Аппликатура / 指法表 / 운지표

The chart displays two saxophone models: Soprano (Tenor) and Soprano Alto. The Soprano Alto model has fingerings 10, 11, 12, and 13 labeled. The chart includes musical notation for a scale in G major (Soprano) and F major (Soprano Alto). Below the notation is a grid of fingerings for each note, represented by black circles (fingered) and white circles (unfingered). The grid has 14 rows and 24 columns.

Instrument	1	2	3	4	5	6	7	8	9	10	11	12	13	14	15	16	17	18	19	20	21	22	23	24
Soprano (Tenor)	●	●	●	●	●	●	●	●	●	○	●	○	○	○	○	○	○	○	○	○	○	○	○	○
Soprano Alto	●	●	●	●	●	●	●	●	●	○	○	○	○	○	○	○	○	○	○	○	○	○	○	○
14	●	●	●	●	●	●	●	●	●	○	○	○	○	○	○	○	○	○	○	○	○	○	○	○
13	●	●	●	●	●	●	●	●	●	○	○	○	○	○	○	○	○	○	○	○	○	○	○	○
12	●	●	●	●	●	●	●	●	○	○	○	○	○	○	○	○	○	○	○	○	○	○	○	○
11	●	●	●	●	●	●	○	○	○	○	○	○	○	○	○	○	○	○	○	○	○	○	○	○
13	●	●	●	●	●	○	○	○	○	○	○	○	○	○	○	○	○	○	○	○	○	○	○	○
12	●	●	●	●	○	○	○	○	○	○	○	○	○	○	○	○	○	○	○	○	○	○	○	○
11	○	○	○	○	○	○	○	○	○	○	○	○	○	○	○	○	○	○	○	○	○	○	○	○
10	○	○	○	○	○	○	○	○	○	○	○	○	○	○	○	○	○	○	○	○	○	○	○	○

- 2つの運指がある音は、左が標準で右はかえ指です。
- ソプラニーノとソプラノはこの記譜よりも実際は1オクターブ上の音が鳴ります。
- If two or more fingerings are shown, the one on the left is standard and the other(s) is the alternate.
- The actual soprano and sopranino tone ranges sound an octave higher than indicated in the chart.
- Falls zwei oder mehr Fingersätze angegeben sind, so ist der linke der übliche und der (die) andere(n) nach Belieben anzuwenden.
- Die wirklichen Tonbereiche der Sopran- und Sopranino-Blockflöten liegen eine Oktave höher als in der Tabelle angegeben.
- Si deux doigtés ou plus sont indiqués, celui de gauche est le doigté standard. L'autre (ou les autres) sont les doigtés alternatifs.
- Les gammes de tonalité réelles de la soprano et de la sopranino sont un octave plus haut qu'il n'est indiqué dans le tableau.
- Si se muestran dos o más digitaciones, la de la izquierda es la estándar y la otra u otras son alternativas.
- Las verdaderas escalas de soprano y sopranino son una octava más alta que la que se indica en el cuadro.
- Se dois ou mais dedilhados são mostrados, o da esquerda é padrão e o(s) outro(s) alternativo.
- Na soprano e sopranino a altura real varia uma oitava acima do indicado no gráfico.
- Если приведены две или более аппликатуры, то та, что слева, считается стандартной, а другие считаются альтернативными.
- Фактический звуковой диапазон сопрано и сопранино на октаву выше, чем указано в нотах.
- 如果图示两个或多个指法，则左侧为标准指法，右侧为替换指法。
- 实际的高音笛及超高音笛音域发出高于表中所注的八度音。
- 두 개 이상의 운지가 표시된 경우에는 왼쪽이 표준이며 오른쪽은 그것을 대체하는 것입니다.
- 실제의 소프라노와 소프라니노 음역은 차트에 표시된 것보다 한 옥타브 높은 소리가 납니다.



開く  
Open  
Offen  
Ouvvert  
Abierto  
Aberto  
Открыто  
全开(不按鍵)  
열림



1/3 ~ 1/4 開く  
1/3-1/4 open  
1/3-1/4 geöffnet  
1/3-1/4 ouvert  
1/3-1/4 abierto  
1/3-1/4 aberto  
Открыто на 1/3-1/4  
开鍵 1/3 ~ 1/4  
1/3-1/4 열림



閉じる  
Closed  
Geschlossen  
Bouché  
Cerrado  
Fechado  
Закрыто  
全閉  
닫힘



A, B 共閉じる  
Close A and B  
Geschlossen A und B  
Bouché A et B  
Cerrado A y B  
A e B fechados  
Закрыты A и B  
閉合 A 和 B  
A 및 B 닫힘



A 閉じる, B 開く  
Close A, Open B  
Geschlossen A, Offen B  
Bouché A, Ouvvert B  
Cerrado A, Abierto B  
A fechado, B aberto  
Закрыто A, открыто B  
閉合 A, 开启 B  
A 닫힘, B 열림

この取扱説明書はエコパルプ (ECF: 無塩素系漂白パルプ) を使用しています。

This document is printed on chlorine free (ECF) paper with vegetable oil ink.

Auf Umweltpapier mit Pflanzenöl Tinte gedruckt.

Ce document a été imprimé sur du papier non blanchi au chlore avec de l'encre de l'huile végétale.

Este documento se ha impreso en papel sin cloro alguno, con tinta de aceite vegetal.

Este documento foi impresso em papel livre de cloro (ECF) com tinta óleo vegetal.

Данный документ напечатан на бумаге, не содержащей газообразного хлора (ECF), с использованием растительное масло чернила.

本文采用植物油墨在无氯 (ECF) 纸张上印刷。

본 설명서는 무염소계 (ECF) 용지에 식물유 잉크를 사용해서 인쇄되었습니다.



この取扱説明書は植物油インキを使用しています。



2 5 0 0 8 6 2



2500862

1604 POCP-C0 版次 201604