

YAMAHA KX-W900U

Natural Sound Stereo Twin Cassette Deck

Various Operations Conventionally Carried Out with 2 Cassette Decks

Dolby B/C NR and HX Pro Dynamic Bias Servo System

Super Bias Oscillator for Low Distortion and High Speed Dubbing

Various Dubbing Operations at Normal/High Speed

Relay Record/Relay Play

Random Program Play, Music Search, Skip Search and Intro Scan

Auto Rec Mute/Auto Rec Return, Remaining Tape Counter

Wireless Remote Control for Major Operations at Listening Position

Thank you for purchasing the YAMAHA KX-W900U stereo twin cassette deck.

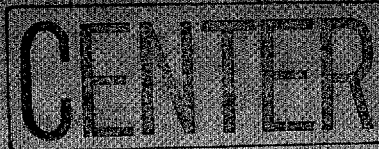

OWNER'S MANUAL



TABLE OF CONTENTS

Safety Instructions	1
Front Panel Parts and Functions	3
Remote Control Transmitter	8
Connections	12
Cassette Tapes	13
Operation	14
Maintenance	22
Troubleshooting	23
Specifications	25

IMPORTANT

Please record the serial number of your unit in the space below.

Model: **KX-W900U**

Serial No:

The serial numbers is located on the rear of the unit.

Retain this Owner's Manual in a safe place for future reference.

WARNING

To prevent fire or shock hazard, do not expose this appliance to rain or moisture.

SAFETY INSTRUCTIONS

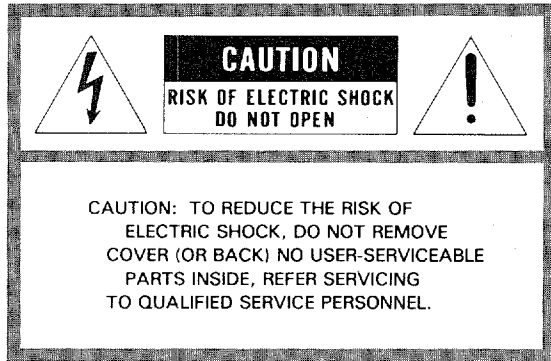

• Explanation of Graphical Symbols

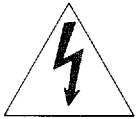

The lightning flash with arrowhead symbol, within an equilateral triangle, is intended to alert you to the presence of uninsulated "dangerous voltage" within the product's enclosure that may be of sufficient magnitude to constitute a risk of electric shock to persons.



The exclamation point within an equilateral triangle is intended to alert you to the presence of important operating and maintenance (servicing) instructions in the literature accompanying the appliance.

WARNING

To prevent fire or shock hazard, do not expose this appliance to rain or moisture.

- 1** Read Instructions – All the safety and operating instructions should be read before the appliance is operated.
- 2** Retain Instructions – The safety and operating instructions should be retained for future reference.
- 3** Heed Warnings – All warnings on the appliance and in the operating instructions should be adhered to.
- 4** Follow Instructions – All operating and other instructions should be followed.
- 5** Water and Moisture – The appliance should not be used near water – for example, near a bathtub, washbowl, kitchen sink, laundry tub, in a wet basement, or near a swimming pool, etc.
- 6** Carts and Stands – The appliance should be used only with a cart or stand that is recommended by the manufacturer.
- 6A** An appliance and cart combination should be moved with care. Quick stops, excessive force, and uneven surfaces may cause the appliance and cart combination to overturn.
- 7** Wall or Ceiling – The appliance should be mounted to a wall or ceiling only as recommended by the manufacturer.

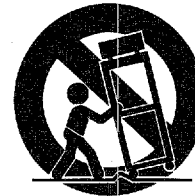

- 8** Ventilation – The appliance should be situated so that its location or position does not interfere with its proper ventilation. For example, the appliance should not be situated on a bed, sofa, rug, or similar surface, that may block the ventilation openings; or cabinet that may impede the flow of air through the ventilation openings.
- 9** Heat – The appliance should be situated away from heat sources such as radiators, stoves, or other appliances that produce heat.
- 10** Power Sources – The appliance should be connected to a power supply only of the type described in the operating instructions or as marked on the appliance.
- 11** Power-Cord Protection – Power-supply cords should be routed so that they are not likely to be walked on or pinched by items placed upon or against them, paying particular attention to cords at plugs, convenience receptacles, and the point where they exit from the appliance.
- 12** Cleaning – The appliance should be cleaned only as recommended by the manufacturer.
- 13** Nonuse Periods – The power cord of the appliance should be unplugged from the outlet when left unused for a long period of time.
- 14** Object and Liquid Entry – Care should be taken so that objects do not fall into and liquids are not spilled into the inside of the appliance.

**CAUTION: READ THIS BEFORE
OPERATING YOUR UNIT.**

15 Damage Requiring Service – The appliance should be serviced by qualified service personnel when:

- A.** The power-supply cord or the plug has been damaged; or
- B.** Objects have fallen, or liquid has been spilled into the appliance; or
- C.** The appliance has been exposed to rain; or
- D.** The appliance does not appear to operate normally or exhibits a marked change in performance; or
- E.** The appliance has been dropped, or the cabinet damaged.

16 Servicing – The user should not attempt to service the appliance beyond those means described in the operating instructions. All other servicing should be referred to qualified service personnel.

1. This unit is a sophisticated stereo cassette deck. To ensure proper operation for the best possible performance, please read this manual carefully.

2. Choose the installation of your unit carefully. Avoid placing it in direct sunlight or close to source of heat. Also avoid locations subject to vibration and excessive dust, heat, cold or moisture. Keep it away from such sources of hum as transformers or motors.

3. Do not open the cabinet as this may result in damage to the deck or electrical shock. If a foreign object should get into the deck, contact your local dealer.

4. When removing the power plug from the wall outlet, always pull directly on the plug; never pull the cord itself.

5. Do not use force when operating switches and knobs.

6. When moving the deck, be sure to first pull out the power plug and remove all cords connecting the deck to other equipment.

7. Do not attempt to clean this unit with chemical solvents as this may damage the finish. Use a clean, dry cloth.

8. Never allow metallic items (e.g. screwdrivers, tools, etc.) to come near the record/playback head assembly. Doing so may not only scratch or damage the head's mirror-smooth finish, it may change the magnetic characteristics of the heads, causing a deterioration in reproduction performance quality.

9. Although the record/playback head used in this unit is a high quality Amorphous head with outstanding reproduction characteristics, it can become dirty through the use of old tapes of from dust accumulation over time. This can have a serious effect on reproduction quality. Clean the heads regularly with one of the commonly available head cleaners or with cleaning solutions as explained later in this manual.

10. Be sure to read the "Troubleshooting" section of this manual for advice on common operating errors before concluding that your unit is faulty.

11. Keep this manual in a safe place for future reference.

KX-W900U

FRONT PANEL PARTS AND FUNCTIONS

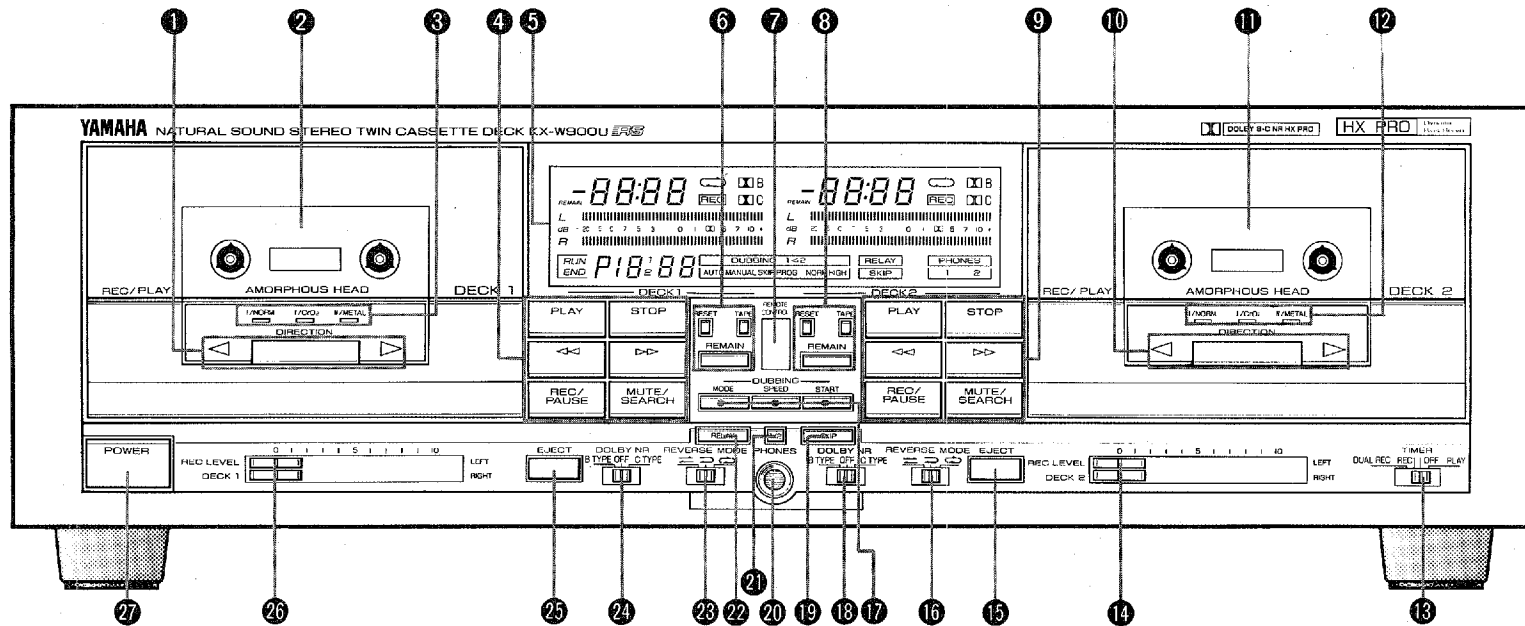

1 DECK 1 DIRECTION button and indicators

DIRECTION button: Selects the tape running direction. The last tape running direction is memorized when the power is turned off.

Direction indicators: Either indicator indicates the tape running direction. When the tape runs from left to right (forward direction), "▶" lights, while the tape runs from right to left, "◀" lights (reverse direction).

2 DECK 1 cassette compartment

3 DECK 1 tape type indicators

When a tape is loaded, the deck's circuitry will automatically adjust for proper bias, level, and equalization for that type of tape, and the type of tape will be indicated.

- Automatic tape selection does not function for the old type metal tapes which do not have a detection hole on the cassette shell.
- This deck is not suited for use with Ferrichrome (FeCr) tapes.

4 DECK 1 main operation buttons

PLAY: Press for playback. It is also necessary to use this button to engage the record mode.

STOP: Press this button to stop the tape while in any mode.

◀◀: Press this button to rapidly move the tape from right to left. To release the rewind mode, press the STOP button.

▶▶: Press this button to rapidly move the tape from left to right. To release the fast forward mode, press the STOP button.

REC/PAUSE: Pressing this button engages the Rec Standby mode, and REC indicator will light. While in this mode, the peak level meters will function, allowing you to monitor the recording signal level of your program source. (Refer to the "SETTING RECORDING LEVEL" section of this manual.) To initiate recording from the Rec Standby mode, press the PLAY button. Pressing the REC/PAUSE button during actual recording engages the Pause mode. To resume recording, press the PLAY button.

MUTE/SEARCH:

During Recording: When the MUTE/SEARCH button is pressed at any time during recording, a 4-second blank interval is automatically recorded on the tape (Auto Rec Mute mode). Then, the Rec Pause mode is engaged automatically. In order to record a blank interval longer than 4 seconds, press the MUTE/SEARCH button and hold it in for the desired length of time. After the button is released, the 4-second blank interval will also be recorded automatically, then the Rec Pause mode is engaged automatically.

To resume recording, press the PLAY button.

During Playback: By pressing either the ►► or ◀◀ button simultaneously with this button, the tape will move to the beginning of the current or next selection, from which point play will be resumed.

5 Display

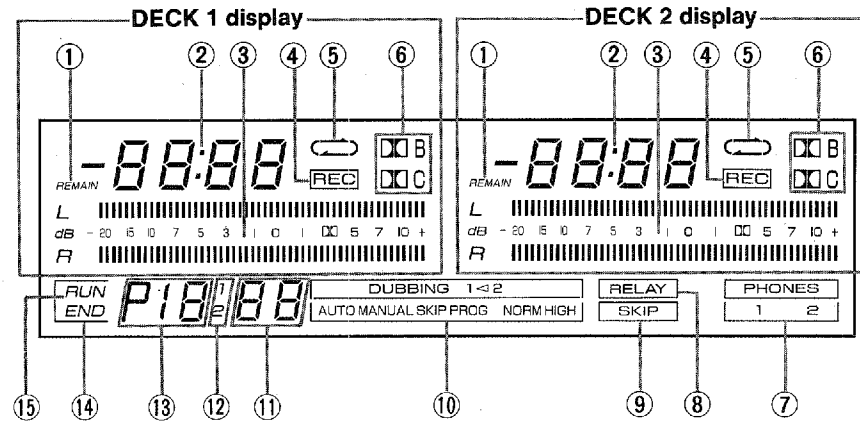

1 REMAIN indicator

By pressing the REMAIN button, this indicator flickers then lights for 5 seconds and the display shows the remaining tape time.

2 Linear counter/tape length/remaining time display

Linear counter: Displays the elapsed time of the tape's running.

* The linear counter is not a actual watch and its accuracy of the linear counter depends on the kind of the tape used.

Tape length: Displays the tape length (C60, C90, C46 and C46L) by pressing the TAPE button.

Remaining time: Displays remaining tape time by pressing REMAIN button.

3 Peak level meters

Indicate the peak of the signal level during recording and playback over a range from -20 dB to +10 dB.

4 REC indicator

This indicator will light up during recording and rec/pause modes. It will flicker during the auto rec mute mode.

5 Reverse mode indicator

Indicates the reverse mode according to the REVERSE MODE selector setting.

6 Dolby B and C NR indicators

The corresponding noise reduction indicator will light up by setting of the DOLBY NR selector.



KX-W900U

⑦ PHONES 1/2 indicator

Indicates selected PHONES 1 or 2 with the PHONES 1/2 button.

⑧ RELAY indicator

Lights when the RELAY button is pressed.

⑨ SKIP indicator

Lights when the SKIP button is pressed or during skip dubbing.

⑩ DUBBING mode indicators

DUBBING 1 ◀ 2: Flickers during tape dubbing execution.

AUTO: Lights during auto dubbing.

MANUAL: Lights during manual dubbing.

SKIP: Lights during skip dubbing.

PROG: Lights during program dubbing.

NORMAL: Lights during standard speed dubbing.

HIGH: Lights during double speed dubbing.

⑪ Selection number display

Displays the selection number to be memorized.

⑫ DECK 1/2 indicator

Indicates either deck 1 or 2 selected with the deck 1/2 key on the remote control transmitter.

⑬ Program number display

Displays the program number.

⑭ END indicator

Lights when the program execution terminates.

⑮ RUN indicator

Lights when the RUN key on the remote control transmitter is pressed for the program execution.

⑯ DECK 1 counter operation buttons

RESET button: Press this button to reset the counter reading to "00:00".

TAPE button: Used to memorize the tape length. Each time this button is pressed, display shows

C-60 → C-90 → C-46 → C-46L and the displayed tape length is memorized.

REMAIN button: When the tape length is memorized with TAPE button, display shows the remaining tape time by pressing this button during playback or recording.

⑰ REMOTE CONTROL sensor

Receives the signal from the remote control transmitter.

⑱ DECK 2 counter operation buttons

Same as the buttons ⑯.

⑲ DECK 2 main operation buttons

Same as the buttons ⑱.

⑳ DECK 2 DIRECTION button and indicators

Same as the button and indicators ⑰.

㉑ DECK 2 cassette compartment

㉒ DECK 2 tape type indicators

Same as the indicators ⑳.

㉓ TIMER selector

OFF: For normal playback or recording, set to this position.

PLAY: By using a commercially available audio timer, this function permits timer activated playback, so you can wake-up to your favorite music, etc.

REC: By using a commercially available audio timer, this function allows you to carry out unattended recording.

DUAL REC: By using a commercially available audio timer, this function allows you to carry out unattended simultaneous recording on both DECKs 1 and 2.

- Be sure to set this selector to OFF when not using the timer feature. If power is turned on with a cassette (cassettes) loaded in the deck(s) and the selector in the REC (or DUAL REC) position, the record mode will be engaged and the prerecorded contents of the tape will be erased.

㉔ DECK 2 REC LEVEL controls

Same as the controls ㉔.

㉕ DECK 2 EJECT button

Same as the button ㉕.

㉖ DECK 2 REVERSE MODE selector

Same as the selector ㉖.

17 DUBBING MODE/SPEED/START buttons

This unit permits dubbing from DECK 2 to DECK 1. The DUBBING MODE button is used to select the dubbing mode. Each time the DUBBING MODE button is pressed, auto, manual, skip or program dubbing mode can be selected and the corresponding indicator lights on the display. Each time the DUBBING SPEED button is pressed, either normal or high speed can be selected and the corresponding indicator lights on the display.

When the NORM indicator lights, the dubbing will start at standard speed and when the HIGH indicator lights, the dubbing will start at high speed. The normal speed dubbing permits Cross-Dolby NR dubbing. Cross-Dolby NR dubbing, with which non Dolby NR encoded tape can be made from a Dolby NR encoded tape, or vice-versa.

After setting of the DUBBING MODE and SPEED buttons, press the DUBBING START button to start dubbing.

18 DECK 2 DOLBY NR selector

Same as the selector 24.

19 SKIP button

Used to skip (fast-forward) the non-recorded section of more than 15 seconds to the next selection for playback.

20 PHONES jack

Connect headphones to this jack for monitoring recording or playback.

21 PHONES 1/2 button

Used to select the monitoring sound between DECKs 1 and 2 when using the headphones.

22 RELAY button

For relay play and relay recording, press this button so that the RELAY indicator lights on the display.

The tape running patterns are different according to the REVERSE MODE selector setting.

REVERSE MODE selector setting		Relay pattern
DECK 1	DECK 2	
		DECK 1 (▶ or ◀) → DECK 2 (▶ or ◀)
		DECK 1 (▶ or ◀) → DECK 2 (▶ → ◀)
		DECK 1 (▶ → ◀) → DECK 2 (▶ or ◀)
		DECK 1 (▶ → ◀) → DECK 2 (▶ → ◀)
		DECK 1 (▶ → ◀) → DECK 2 (▶ or ◀)
		DECK 1 (▶ → ◀) → DECK 2 (▶ → ◀)
		DECK 1 (▶ → ◀) → DECK 2 (▶ → ◀)

* The relay playback repeats up to 8 times in this way, but the recording stops after termination of reverse side recording on DECK 2.



- When the relay playback or relay recording starts on reverse side (◀), playback or recording does not change to forward side (▶) of the same tape but shifts to other deck.
- The relay recording can be executed only when the recording starts from DECK 1.

- By setting of both DECKs 1 and 2 REVERSE MODE selectors to (), relay playback can be executed even when the playback starts from DECK 2. In this operation, the tape on DECK 1 is repeatedly played back 7 times and the tape on DECK 2 is repeatedly played back 8 times.

KX-W900U

23 DECK 1 REVERSE MODE selector

Used to select tape running patterns.

Mode Setting	Tape running patterns		
	Playback	Recording	Fast-forwarding
	One side of a tape is played back.	One side of a tape is recorded.	The tape stops at the tape end.
	After the forward side (▶) of a tape is played back, the reverse side (◀) is played back. The tape stops at the tape end.	After the forward side (▶) of a tape is recorded, the reverse side (◀) is recorded. The tape stops at the tape end.	After termination of fast-forwarding (▶▶) the forward side of a tape, the reverse side (◀) is played back. The tape stops at the tape end.
	Both sides of a tape are repeatedly played back (up to 8 plays).		After termination of fast-forwarding (▶▶) the forward side of a tape, the reverse side (◀) is played back. After termination of fast-forwarding (◀◀) the reverse side of a tape, the forward side (▶) is played back.

NOTE:

- This unit uses a light sensor to detect the tape leader for quick auto-reverse. Occasionally, tapes have colored leaders — this may cause the quick auto-reverse to malfunction. In this case, the tape will reverse after it reaches the end. Also, sunlight or artificial light shining directly on the front of the deck may cause the quick auto-reverse to malfunction.

- Quick reverse does not function if recording or playback is activated with less than 10 seconds of tape remaining.
- In the  mode, the quick reverse does not function.

24 DECK 1 DOLBY NR selector

OFF: For recording and playback without using the DOLBY NR, set to this position.

B TYPE, C TYPE: Dolby noise reduction is an extremely effective method of reducing background hiss on tapes. This unit incorporates both Dolby B NR and the newer Dolby C NR system. Dolby C NR is approximately twice as effective as Dolby B NR.

Tapes recorded with Dolby B NR should be played back with Dolby B NR, set this selector to B TYPE position. Tapes recorded with Dolby C NR should be played back with Dolby C NR, set this selector to C TYPE position.

* Dolby and the double D mark are trademarks of Dolby Laboratories Licensing Corp. Dolby noise reduction system manufactured under license from Dolby Laboratories Licensing Corp.

25 DECK 1 EJECT button

To load a cassette tape, press the EJECT button and the cassette compartment will open. Depress the cassette compartment to close it.

26 DECK 1 REC LEVEL controls

Adjusts the input level of the recording signal coming from the rear panel LINE IN/REC jacks, and adjustable signal level is displayed on the peak level meters. Independent left/right controls also permit balance level setting.

27 POWER switch

Press this switch to turn the power on. Press again to turn the power off.

REMOTE CONTROL TRANSMITTER

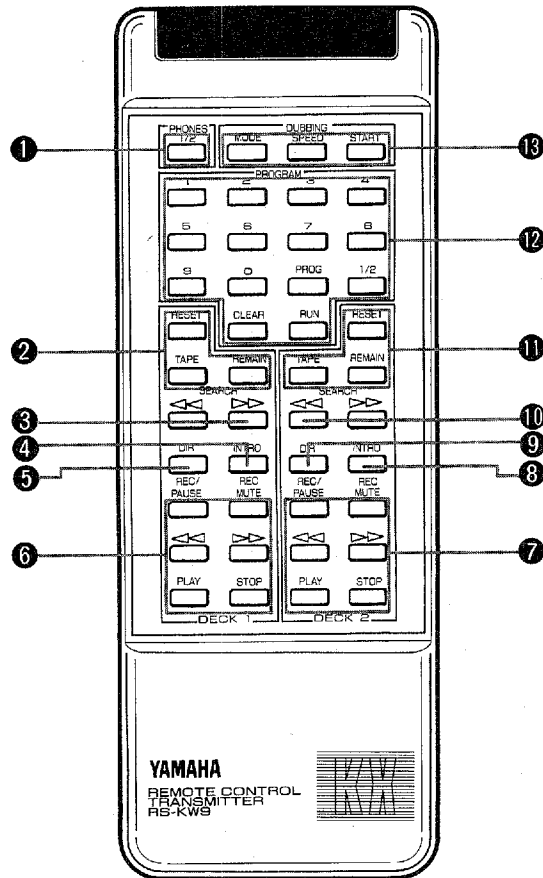

① PHONES 1/2 key

This key has the same function as that on the main unit.

② DECK 1 counter operation keys

These keys have the same functions as those on the main unit.

③ DECK 1 SEARCH keys

- When the tape runs from left to right (▶)
 - ◀◀: By pressing this key, the tape will be moved to the beginning of the current selection.
 - ▶▶: By pressing this key, the tape will be moved to the beginning of the next selection.
- When the tape runs from right to left (◀)
 - ◀◀: By pressing this key, the tape will be moved to the beginning of the next selection.
 - ▶▶: By pressing this key, the tape will be moved to the beginning of the current selection.

It is also used to directly select the selection if the selection number is selected with numeric keys.

④ DECK 1 INTRO key

Press this key to play back the beginning of the selection for about 10 seconds in the selected direction.

⑤ DECK 1 DIR (Direction) key

This key has the same function as that on the main unit.

⑥ DECK 1 main operation keys

These keys have the same functions as those on the main unit.

⑦ DECK 2 main operation keys

These keys have the same functions as those on the main unit.

⑧ DECK 2 INTRO key

Same as the key ④.

⑨ DECK 2 DIR (Direction) key

This key has the same function as that on the main unit.

⑩ DECK 2 SEARCH keys

Same as the keys ③.

⑪ DECK 2 counter operation keys

These keys have the same functions as those on the main unit.

⑫ Program operation keys

Numeric (1-0) keys: Used to directly select the selection number to be played.

PROG key: Used to memorize the selection number to be programmed, check or correct the program content.

Deck 1/2 key: Used to select between DECKs 1 and 2.

CLEAR key: Used to clear the memorized program.

RUN key: Press this key for program execution.

⑬ DUBBING keys

These keys have the same functions as those on the main unit.

KX-W900U

■ BATTERY INSTALLATION

- ① Slide out the battery compartment lid in the direction of the arrow.
- ② Install the batteries (size "AA", R06) with correct polarities.
- ③ Attach the battery compartment lid until it clicks.

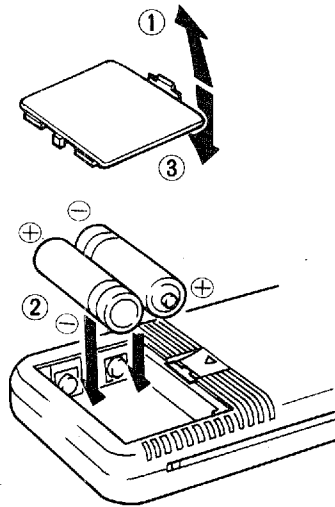

■ REMOTE CONTROL OPERATION RANGE

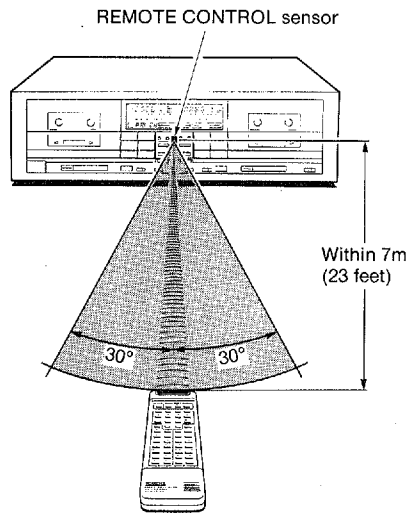

■ BATTERY REPLACEMENT

When the remote controllable distance becomes short, batteries are exhausted. Replace two batteries with new ones.

Battery cautions

Incorrect use of the battery may cause leakage or explosion.

Be careful the following items:

When replacing:

- Place the batteries in correct (+) and (-) polarities as indicated in the battery compartment.
- Do not use the old battery together with new one.
- Do not use the different kind of batteries at the same time even though in the same shape.

Rechargeable batteries:

- There are two kinds of batteries in the market: rechargeable and non-rechargeable. Read the caution labels on the battery carefully.

Use with the remote control transmitter:

- When not in use for an extended period of time, remove the batteries from the remote control transmitter.
- Replace the exhausted batteries earlier in good time.

To prevent accident:

- Never disassemble, heat the battery, or throw into the fire. Dispose the batteries in the specified places.
- Do not connect (short) (+) and (-) directly with the metal piece, etc.

In case of leakage:

Wipe off the electrolyte in the battery compartment completely before replace with the new batteries.

KX-W900U



DOLBY C TYPE NOISE REDUCTION

With cassette tapes, the most noticeable form of noise is high frequency hiss. To reduce this hiss noise, the KX-W900U has been equipped with a newly developed Dolby C noise reduction system in addition to its conventional Dolby B NR. Either type of noise reduction may be selected with the switch provided. Dolby B NR has a noise reduction effect of about 10 dB in the high frequency range. The corresponding figure with Dolby C NR is about 20 dB, but this is over the entire range where the human ear is most sensitive to noise (2 kHz to 8 kHz). Dolby C NR also improves the tape's MOL (Maximum Output Level). Dolby C NR has two new circuits; a spectral skewing circuit and an anti-saturation network. By improving the saturation level of the tape it is possible to prevent high frequency loss and encode/decode error, etc., improve dynamic range and signal-to-noise ratio, and make it easier to set the recording level. With Dolby C NR it is possible to achieve the same noise reduction effect at both high and low signal levels and to set the recording level at a point where side effects such as "breathing" are eliminated. Also, by expanding the operating frequency range to two octaves more than that of Dolby B NR, overall noise balance is obtained and the system also becomes effective against high frequencies from the power supply.

The graph shows the frequency response and the noise reduction effect of recording and playback with Dolby B NR and Dolby C NR. The noise reduction effect of Dolby C NR is larger — approximately 20 dB. Dolby noise reduction is a 2 part process that acts both on recording and playback; be sure that the noise reduction button is set to the same position on record and play.

* Noise in the source material cannot be reduced with the Dolby NR system.

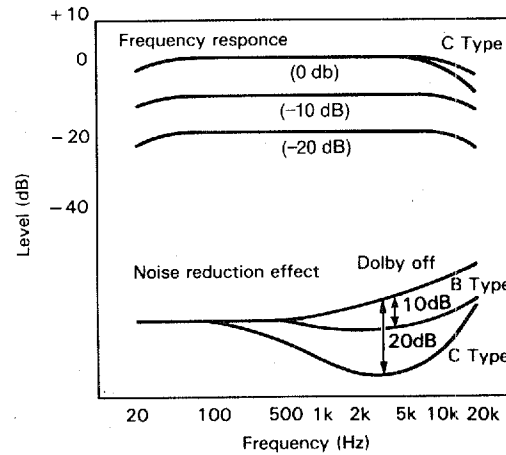

HX PRO DYNAMIC BIAS SERVO SYSTEM

Even when the recording bias is set by built-in auto tape selector according to the type of tape used, the high frequency content of the recording signal tends to increase the set bias, causing loss of high frequency headroom, tape saturation and intermodulation distortion in the low-frequency range.

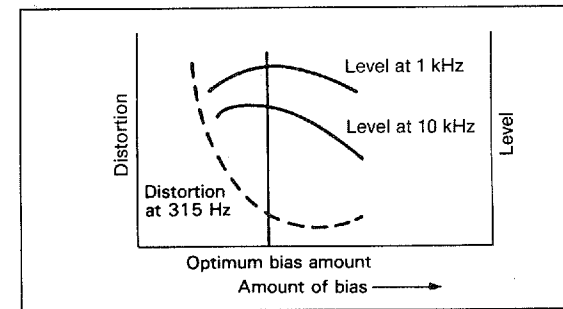

To prevent this problem, the HX Pro Dynamic Bias Servo circuit constantly monitors the total effective bias during recording and instantly lowers the increased bias, keeping the total bias constant.

The circuit works independently on each channel, and no decoding is necessary during playback.



KX-W900U

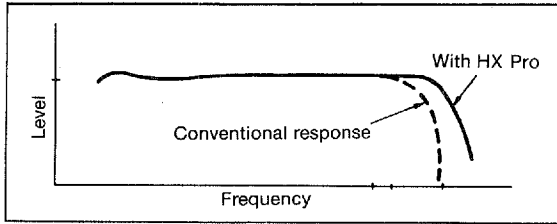

* The HX Pro is not the noise reduction system. Since it functions only in recording, the tape recorded with HX Pro system can be played back on any types of cassette decks, with a richer dynamic range.

Dolby Noise reduction and HX Pro headroom extension manufactured under license from Dolby Laboratories Licensing Corporation. HX Pro originated by Band & Olufsen.

“DOLBY”, the double-D symbol  and “HX PRO” are trademarks of Dolby Laboratories Licensing Corporation.

KX-W900U

CONNECTIONS

* To obtain full performance of this unit, use the amplifier having 2 pairs of Tape Input/Output jacks. When the amplifier has only 1 pair of

Tape Input/Output jacks, some operation cannot be carried out.

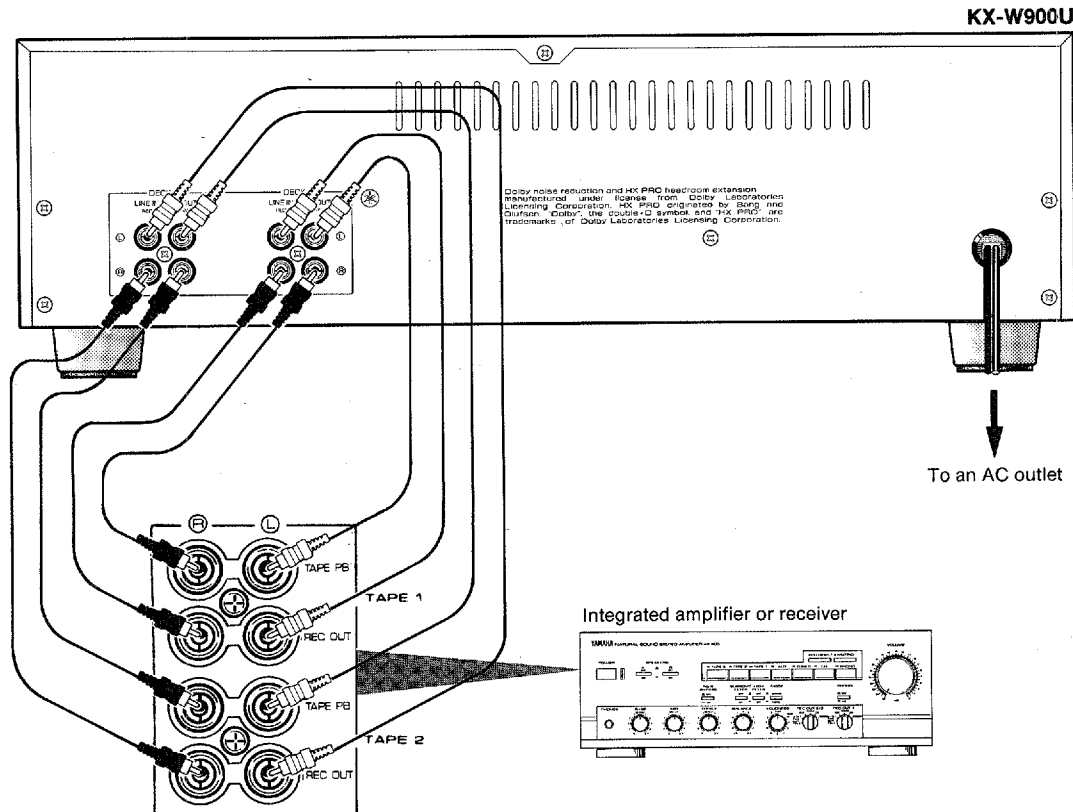

REAR PANEL CONNECTIONS

The White plug on the paired connecting cables corresponds to the Left channel and the Red plug corresponds to the Right channel. The DECK 1 LINE OUT/PLAY jacks on the rear panel should be connected to the TAPE 1 TAPE PB (Playback/Input) jacks on your integrated amplifier or receiver, and the DECK 1 LINE IN/REC jacks should be connected to the TAPE 1 REC OUT (Recording/Output) jacks on your integrated amplifier or receiver. The DECK 2 LINE OUT/PLAY jacks on the rear panel should be connected to the TAPE 2 TAPE PB (Playback/Input) jacks on your integrated amplifier or receiver, and the DECK 2 LINE IN/REC jacks should be connected to the TAPE 2 REC OUT (Recording/Output) jacks on your integrated amplifier or receiver. Make sure that the left and right channel connections are properly made, and that the plugs are inserted firmly.

Connect the power cord to an AC outlet or to the AC outlet provided on the rear panel of your receiver or integrated amplifier, etc. Make sure that power to both the KX-W900U and your integrated amplifier (receiver, etc.) are turned off before making connections.

KX-W900U

CASSETTE TAPES

■ CASSETTE TAPES

There are many different types of cassette tapes available, however, they all conform to standard specifications so any brand may be used with the KX-W900U.

* Classification of Cassettes Tapes by Formulation

Cassette tapes are available in four basic types depending on their formulation, or type of magnetic material and manufacturing process. These four types are commonly known as Normal (I/NORM), Chrome (II/CrO₂), Ferrichrome (III/FeCr), and Metal (IV/METAL), and they each require specific optimum performance. The KX-W900U has an Auto Tape Selector which automatically adjusts for the proper bias, level and equalization according to the tape formulation — all you have to do is load a cassette and the Auto Tape Selector does the rest.

* Old-type Metal tape cassette shells do not have the necessary hole for Auto Tape Selector operation. It is recommended that you do not record with this kind of Metal cassette. However, Metal tape cassettes recorded on another deck may be played back with the KX-W900U at the Chrome (II/CrO₂) settings. All current cassette tapes will have this small opening in the cassette shell, so be sure you use suitable cassettes with the KX-W900U.

* The KX-W900U does not have the required setting for Ferrichrome (III/FeCr) tape, since this tape formulation is not widely used. Should you use a Ferrichrome tape, it will be recorded and played back at the Normal (I/NORM) settings. And this will result in an unnatural high frequency emphasis.

This effect may be compensated for somewhat by adjusting the tone controls of your amplifier.

* YAMAHA does not recommend the use of C-120 cassettes since the extreme thinness of the tape makes them susceptible to mechanical and electrical problems.

■ PROTECTING YOUR RECORDINGS

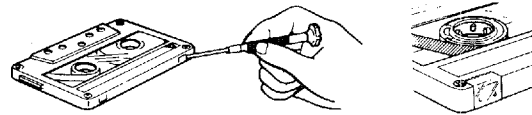

All cassette tapes are provided with erasure protection holes to prevent recorded tapes from being accidentally erased. There is a small tab covering the hole on each cassette, and it should be broken off with the screwdriver after recording a tape. Without this tab covering the hole, it is impossible to record on that tape again; thus, you can keep any recorded tape for as long as you wish without fear of accidental erasure. Should you wish to use a cassette tape protected in this way for later recording, simply covering the hole with adhesive tape will permit erasure and re-recording.

* When using Chrome (II/CrO₂) or Metal (IV/METAL) tape, make sure you do not cover the hole intended for the tape formulation check.

■ TAKING UP SLACK IN THE TAPE

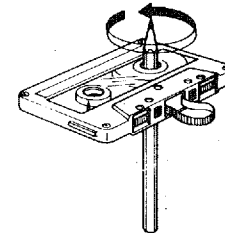

Slack in the tape inside of the cassette shell can be corrected by simply inserting a pencil into one of the spools and winding it until all the slack is taken up.

■ STORAGE OF YOUR CASSETTE

After putting a cassette tape back into its case, store in a location away from exposure to direct sunlight, humidity, high temperatures, and magnetic fields (away from television sets, speakers, etc.). High temperatures and humidity will damage the tape itself, while exposure to magnetic fields may cause a loss of recorded material.

OPERATION

RECORDING (common to both DECKS 1 and 2)

1. Make sure that the TIMER selector is set to the OFF position, then turn on the POWER switch.
2. Open the cassette compartment by pressing the EJECT button and load a cassette tape with the exposed tape face down.
3. Select the noise reduction system with DOLBY NR selector.
4. Select the tape running direction by pressing the DIRECTION button.
5. Set the REVERSE MODE selector as required.
6. Press the REC/PAUSE button. The deck enters the Rec Standby mode.
7. Set the amplifier's recording output switch for the source to be recorded, and play the source.
8. Adjust the recording level to optimum point using peak level meters and REC LEVEL controls.
9. Press the PLAY button to start recording. To temporarily stop the recording, press the REC/PAUSE button. To resume the recording, press the PLAY button.
10. To stop recording, press the STOP button.

- When the MUTE/SEARCH button is pressed during recording, a 4-second blank interval is automatically recorded on the tape, then the Rec Pause mode is engaged. To resume recording, press the PLAY button.
- When the tape is rewound during recording, the tape moves to the recording start position and stops automatically. When the counter is reset to "0:00" during recording, the tape is returned to that position (0:00) due to the recording return function.

NOTE:

Please check the laws on copyright in your country to record from records, discs, tapes, radio, etc.

Recording the prerecorded tapes or other published or broadcast material may infringe copyright laws.

SETTING THE RECORDING LEVEL

Setting the recording level is an important point for proper recording. Press the REC/PAUSE button to engage the Rec Standby mode, and play a section of the program to be recorded. Watch the peak level meters and adjust the REC LEVEL controls so that the average meter reading is between 0 dB and +5 dB, with occasional peaks no higher than +7 dB.

KX-W900U

AUTO REC MUTE

Use this function to effectively cut off unwanted material during recording or to provide blank section between selections.

1. Press the MUTE/SEARCH button or REC/MUTE key on the remote control transmitter at the beginning of the section not to be recorded. The unit makes a blank section of about 4 seconds, then enters rec pause mode.
2. To resume recording, press the PLAY button. Keep the MUTE/SEARCH button or REC/MUTE key on the remote control transmitter pressed to provide a blank section of more than 4 seconds.

RELAY RECORDING

Recording can be made continuously on DECKS 1 and 2. Relay recording must be initiated on DECK 1.

1. Make sure that the TIMER selector is set to the OFF position, then turn on the POWER switch.
2. Load cassette tapes to both DECKS 1 and 2.
3. Select the noise reduction system on both DECKS 1 and 2.
4. Select the reverse mode with REVERSE MODE selectors on both DECKS 1 and 2. For tape running patterns, refer to the "RELAY button" section on page 6.
5. Adjust the recording level on both DECKS 1 and 2.

KX-W900U

6. Press the RELAY button so that the RELAY indicator lights.
 7. Press the DECK 1 PLAY button to start relay recording.
- * When both DECK 1 and 2 LINE IN/LINE OUT jacks are not connected, this function cannot be activated.

NOTE:

When the amplifier used has two recording output switches, they should be set for the same recording source subject to relay recording.

■ SIMULTANEOUS RECORDING OF ONE SOURCE

1. Perform steps 1-6 of "RECORDING" section on both DECKs 1 and 2.
 2. Set the amplifier's recording output switch for the source to be recorded, and play the source. When the amplifier used has two recording output switches, they should be set to the same recording source position.
 3. Perform steps 8-10 of "RECORDING" section on both DECKs 1 and 2.
- * Make sure that the RELAY button is set to OFF.
- * When both DECK 1 and 2 LINE IN/LINE OUT jacks are not connected, this function cannot be activated.

■ SIMULTANEOUS RECORDING OF TWO DIFFERENT SOURCES

Example: To record tuner broadcast on DECK 1 and turntable play on DECK 2.

1. Perform steps 1-6 of "RECORDING" section on both DECKs 1 and 2.
 2. Set the amplifier's recording output switches so that the tuner input is output to DECK 1 and turntable input is output to DECK 2.
 3. Perform steps 8-10 of "RECORDING" section on DECKs 1 and 2.
- * Make sure that the RELAY button is set to OFF.
- * When both DECK 1 and 2 LINE IN/LINE OUT jacks are not connected, this function cannot be activated.

■ DUBBING (DECK 2 to DECK 1 only)

Auto dubbing

This function is convenient for creating an identical tape. When the deck (DECK 1 or 2) which comes to the reversing position earlier than the other deck (DECK 2 or 1), the deck enters the standby mode. When the other deck comes to the reversing position, the dubbing can be resumed with the respective leaders of the reverse sides of the tape aligned with each other automatically.

1. Load the blank tape in DECK 1 and the original tape in DECK 2.
2. Press the DUBBING MODE button so that the AUTO indicator lights.

3. Select the dubbing speed either NORM or HIGH with the DUBBING SPEED button. For Cross-Dolby NR dubbing, select the normal speed, and set the DECK 2 DOLBY NR selector according to the tape on DECK 2 and the DECK 1 DOLBY NR selector as desired.
 4. Press the DUBBING START button to start the auto dubbing. At this time, both tapes will move to the beginning of the forward side and the dubbing will start from forward side regardless of the setting of the DIRECTION buttons. Both sides of tape will be dubbed regardless of the setting of the REVERSE MODE selectors.
 5. To stop the dubbing, press the DECK 1 or 2 STOP button. When the DECK 1 STOP button is pressed, both DECKs 1 and 2 stop. When the DECK 2 STOP button is pressed, DECK 2 stops and DECK 1 creates a non-recorded section of about 4 seconds and stops.
- Use tapes of identical length on DECKs 1 and 2.
Use of different length tapes causes halfway cutoff of selections or longer non-recorded sections at the end of the tape.
 - When auto, skip or program dubbing at high speed, recording is made in the tape loaded in DECK 2 as it is independent of the setting of the DECK 1 DOLBY NR selector. When playing back the tape on DECK 1 (recorded side), set the DOLBY NR selector to the same position as for the tape on DECK 2 (playback side).

- The monitor sound during high-speed dubbing becomes high-speed playback sound.

Skip dubbing

This function is convenient for effective dubbing between tapes of different length. For example, both sides of a C-46 tape can be dubbed onto one side of a C-90 by a single action. In addition, when a non-recorded section continues for more than 15 seconds on the playback side tape, this tape is automatically fast-forwarded to the beginning of the next selection. Then, the recorded side tape creates a non-recorded section of about 4 seconds and enters the standby mode. Thus, when the next selection starts, the recording is resumed at the same time. A dubbing tape on which any interval between selections on the original tape is arranged into about 4 seconds on each side is generated.

1. Load the blank tape in DECK 1 and the original tape in DECK 2.
2. Set the REVERSE MODE selectors as desired.
3. Press the DUBBING MODE button so that the SKIP indicator lights.
4. Select the dubbing speed either NORM or HIGH with the DUBBING SPEED button. For Cross-Dolby NR dubbing, select the normal speed, and set the DECK 2 DOLBY NR selector according to the tape on DECK 2 and the DECK 1 DOLBY NR selector as desired.
5. Press the DUBBING START button to start the skip dubbing.

Random programmed dubbing (Using the remote control transmitter)

You can also select 15 selections to be dubbed and rearrange them in your desired order of selections. For the selection numbers, the first selection to the 79th selection can be specified.

Example:

- P1: 3rd selection of forward side on a tape of which 5 selections are recorded.
 P2: 7th selection of reverse side on a tape of which 10 selections are recorded.
1. Set the unit to stop mode.
 2. Press the PROG key. The program number "P1" appears on the program display.
 3. Press the deck 1/2 key so that the deck 2 indicator lights.
 4. Press the numeric "3" key. "P1.3" appears on the program display and the selection number "3" blinks.
- * Be sure to press the numeric key within 20 seconds. Otherwise, the program number goes off and programming is not possible. In this case, press the PROG key to call the program number to be memorized.
- To correct the selection number, press "0" key and then memorize the selection number by pressing numeric key.
5. Press the PROG key to memorize the selection number. The programmed first selection is memorized, program number "P2" appears on the display and the second selection can be selected.

6. For the selection number of the reverse side, add the number of the selections on the forward side (in this example, 5) to each selection number on reverse side. Press the numeric "1" and "2" keys. "P2.12" appears on the display and the selection number "12" blinks.
- When the specified selection exists on the reverse side, set the DECK 2 REVERSE MODE selector to "D" position.
7. Press the PROG key.
 8. Press the DUBBING MODE key so that the PROG indicator lights.
 9. Select the dubbing speed with the DUBBING SPEED key. For Cross-Dolby NR dubbing, select the normal speed, and set the DECK 2 DOLBY NR selector according to the tape on DECK 2 and the DECK 1 DOLBY NR selector as desired.
 10. Press the DUBBING START key to start the program dubbing. The tape will be fully rewound and the dubbing starts in the programmed order. (The program number blinks during music search.) Display shows the program number and the selection number being dubbed. After termination of programmed dubbing, END indicator lights on the display.
- To stop the dubbing on its way, press the DECK 1 or 2 STOP key. When the DECK 1 STOP button is pressed, DECKs 1 and 2 stop. When the DECK 2 STOP button is pressed, DECK 2 stops and DECK 1 creates a non-recorded section of about 4 seconds and stops.

KX-W900U

- When the specified selection number does not exist on the tape, "Err" display appears and the dubbing stops. When this display appears, check the program content.

For check, clearance or correction of program content, refer to "RANDOM PROGRAMMED PLAYBACK" section.

Manual dubbing

This function is convenient for editing the dubbing. It is possible to record the blank interval by pressing the MUTE/SEARCH button or to engage the recording standby mode by pressing the REC/PAUSE button on DECK 1.

1. Press the DUBBING MODE button so that the MANUAL indicator lights.
 2. Press the DUBBING SPEED button so that NORM indicator lights.
 3. For Cross-Dolby NR dubbing, set the DECK 2 DOLBY NR selector according to the tape on DECK 2, and DECK 1 DOLBY NR selector as desired.
 4. Press the DUBBING START button to start manual dubbing.
 5. To release the manual dubbing, press the DECK 1 or 2 STOP button.
- When the tape is rewound during dubbing, the tape moves to the dubbing start position and stops.

■ PLAYBACK DURING RECORDING

1. Load a cassette tape to be recorded in the deck (DECK 1 or 2) and a cassette tape to be played back in the another deck (DECK 2 or 1).
 2. Select the program source to be recorded with the amplifier's recording output selector and set the deck (DECK 1 or 2) to record mode.
 3. To listen to the playback sound of the deck (DECK 2 or 1) during recording, select the amplifier's input selector and set the deck (DECK 2 or 1) to playback mode. For playback, refer to the "PLAYBACK" section.
 4. When using the headphones, the monitoring sound or playback sound can be heard independently by pressing the PHONES 1/2 button.
- * When the DECK 1 and 2 LINE IN/LINE OUT jacks are not connected, this function cannot be activated.

PLAYBACK (Common to DECKs 1 and 2)

1. Make sure that the TIMER selector is set to the OFF position, then turn on the POWER switch.
2. Open the cassette compartment by pressing the EJECT button and load a recorded cassette tape.
3. Press the DIRECTION button to select the tape running direction.
4. Set the REVERSE MODE selector as required.
5. Set the DOLBY NR selector according to the tape recording system.
6. Select the amplifier's input selector for tape playback.
7. Press the PLAY button to start playback.
8. Set the volume and tone controls on the amplifier to adjust sound quality as desired.
9. To stop playback, press the STOP button.

■ RELAY PLAYBACK

1. Load cassette tapes in DECKs 1 and 2.
2. Press the RELAY button so that the RELAY indicator lights.
3. Set the DIRECTION button, REVERSE MODE and DOLBY NR selectors or both DECKs 1 and 2. As the relay patterns are different according to the REVERSE MODE selector setting, refer to the "RELAY button" section on page 6.

* When the DECK 1 and 2 LINE IN/LINE OUT jacks are not connected, this function cannot be activated.

■ BLANK SKIP

When the interval between selections is more than 15 seconds, the tape is automatically fast-forwarded and the playback starts at the next selection. This function will work with the SKIP button pressed either when the tape is to be played back or when the tape is in play.

- With a tape having large noise or when sound of extremely low level continues, the unit may malfunction.

■ INTRO SCAN

During playback or stop mode, press the INTRO key on the remote control transmitter. The beginning of each selection is played back for about 10 seconds in the selected direction with the DIRECTION button. Press the PLAY button while the beginning of the desired selection is being played back to set the unit to normal play mode.

■ SINGLE SELECTION

● When the tape runs from left to right (▶)

By pressing ◀◀ button simultaneously with the MUTE/SEARCH button or by pressing the SEARCH (◀◀) key on the remote control transmitter, the tape will move to the beginning of the current selection from which point play will be resumed.

By pressing ▶▶ button simultaneously with the MUTE/SEARCH button or by pressing the SEARCH (▶▶) key on the remote control transmitter, the tape will move to the beginning of the next selection from which point play will be resumed.

● When the tape runs from right to left (◀)

By pressing ▶▶ button simultaneously with the MUTE/SEARCH button or by pressing the SEARCH (▶▶) key on the remote control transmitter, the tape will move to the beginning of the current selection from which point play will be resumed.

By pressing ◀◀ button simultaneously with the MUTE/SEARCH button or by pressing the SEARCH (◀◀) key on the remote control transmitter, the tape will move to the beginning of the next selection from which point play will be resumed.

■ DIRECT MUSIC SEARCH (Using the remote control transmitter)

Direct music search is possible up to the selection located 99 selections after and 98 selections before that which you are now listening to.

Example: For listening to the selection located 10 selections after.

1. Press "1" key and "0" key on the remote control transmitter. Display indicates "10".
2. When the tape travels in the forward direction (▶), press the SEARCH (▶▶) key. When the tape travels in the reverse direction (◀), press the SEARCH (◀◀) key. The tape will be fast forwarded to the beginning of the selected selection, selection number and deck 1 or 2 indicator will go off, and playback will start automatically. (During music search, deck 1 or 2 indicator blinks.)

- When the specified selection exists on the other side of tape, set the REVERSE MODE selector to "↷" position. The Direct Music Search Play cannot be carried out through the end of tape.
- Be sure to press the SEARCH key within 5 seconds. Otherwise, the direct music search is not possible.

Example: For listening to the located 10 selection before.

1. Press "1" key twice on the remote control transmitter.

KX-W900U

Display indicates "11". When the selection number is set to "10", the beginning of the selection located 9 selections before is searched. In this way, selection is possible up to the selection located 98 selections before.

- When the tape travels in the forward direction (▶), press the SEARCH (◀◀) key. When the tape travels in the reverse direction (◀), press the SEARCH (▶▶) key. The tape will be fast rewound at the beginning of the selected selection, selection number and deck 1 or 2 indicator will go off, and playback will start automatically.
- When the specified selection does not exist on the tape, the tape will be fast forwarded or fast rewound to the end and the direct music search will be cleared.
- When the (◀◀), (▶▶), PLAY or STOP key is pressed while searching, the direct music search will be cleared.

■ RANDOM PROGRAMMED PLAYBACK (Using the remote control transmitter)

You can select 15 selections and rearrange them in your desired order of selections. For the selection numbers, the first selection to the 79th selection can be specified.

Example: P1 — 2nd selection on DECK 1
P2 — 4th selection on DECK 2

- Set the unit to stop mode.
- Press the PROG key on the remote control transmitter. The program number "P1." appears on the display.
- Press the deck 1/2 key so that the deck 1 indicator lights.
- Press "2" key on the remote control transmitter. "P1.2" appears on the display and the selection number "2" blinks.
 - * Be sure to press the numeric key within 20 seconds. Otherwise, the program number goes off and programming is not possible. In this case, press the PROG key to call the program number to be memorized.
- Press the PROG key to memorize the selection number. The programmed first selection is memorized, program number "P2." appears on the display and the second selection can be selected.

- Press the deck 1/2 key so that the deck 2 indicator lights.
- Press "4" key. "P2.4" appears on the display and the selection number "4" blinks.
- Press the PROG key.
- Press the RUN key on the remote control transmitter. The tape will be fully rewound and the playback starts in the programmed order of selection. (The program number blinks during music search.)

Display shows the program number and the selection number which is now playing. After termination of programmed playback, "End" display lights on the display. To stop the playback, press the STOP button.
- Programmed playback does not repeat even when the REVERSE MODE selector is set to "⏮" position. To start programmed playback once again, press the RUN key.
- For the selection number of the reverse side, add the number of the selections on the forward side to each selection number on reverse side.
- Programming is possible during stop, playback, fast forward or fast rewind mode, but programmed playback can start only during stop mode.
- When the specified selection number does not exist on the tape, "Err" display appears and the playback stops. When this display appears, check the program content.

For check program content

1. Press the STOP key.
2. Each time the PROG key is pressed, the memorized selection number and program number are displayed.

For clearance of all the program content

1. Press the STOP key and PROG key.
2. Press the CLEAR key on the remote control transmitter.
- When the POWER switch is pressed to OFF, the content of the program is also cleared.

For correction of the program content

1. Press the STOP key.
2. Press the PROG key to call the program number to be corrected.
3. Press the numeric key according to new selection number.
4. Press the PROG key to memorize the new selection number.

■ SIMULTANEOUS PLAYBACK

1. Load the cassette tapes in DECKs 1 and 2.
2. Perform the steps of "PLAYBACK" on both DECKs 1 and 2.
3. To listen to the sound from DECK 1 or 2, set the amplifier's corresponding input selector.
 - * When using the headphones, the sound from DECK 1 or 2 can be heard independently by pressing the PHONES 1/2 button.
 - * When both DECK 1 and 2 LINE IN/LINE OUT jacks are not connected, this function cannot be activated.

■ FOR TROUBLE-FREE OPERATION

Scan functions are activated based on unrecorded tape sections of specified time. To ensure error-free operation, please follow these procedures:

- Use tape that is free from static or previously recorded music in the sections between selections.
- Do not use with tapes that include selections with long silences.
- Do not use with tapes that include selections with low level passages.
- Do not use with tapes of conversations or other recordings with many interruptions.

Notes on the remote control transmitter

The remote control transmitter which is supplied with the YAMAHA amplifier/receiver (bearing an RS mark) has been designed to control various functions of the YAMAHA components that have remote control compatibility (components with an RS mark).

However, DECK 2 of this unit cannot be controlled by the remote control transmitter supplied with the YAMAHA amplifier/receiver bearing an RS mark. You must use the RS-KW9 remote control transmitter supplied with this unit for a complete operation.

KX-W900U

■ TIMER RECORDING/PLAYBACK

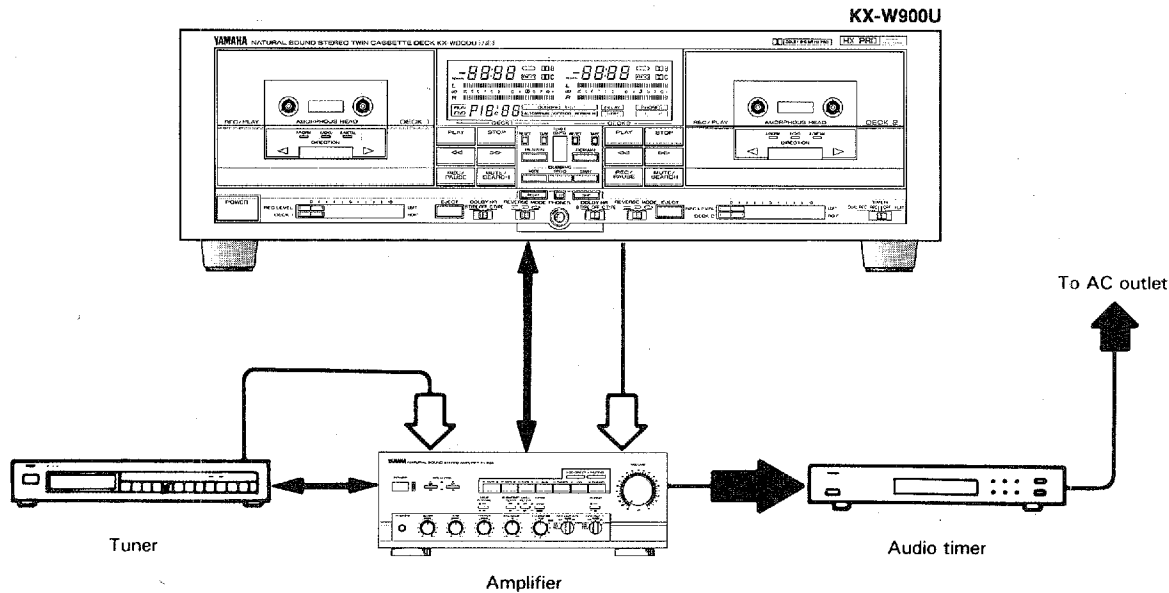

When using the TIMER selector in combination with a commercially available audio timer, it is possible to make recordings and initiate

playback at any time automatically by presetting the deck in advance.

● Timer Recording

1. Make sure that all power cord connections between the timer and amplifier are properly made. No change in any of the other connections between deck and amplifier, etc., is necessary.
2. After turning on the power to each component, select the station on your tuner which you want to record and turn down the volume on your amplifier. This will have no effect on the recording signal level. Remember to set the proper recording level.
3. Set the timer to the desired times. It is advisable to set the timer to begin recording slightly before the actual recording time, and end slightly after the actual recording time, so that you leave some room for later editing.
4. Set the TIMER selector to the REC position.
5. The timer will send power to the amplifier, tuner and deck at the preset time, turning all the components on and initiating the recording mode. The deck in which the tape is loaded starts recording. When the cassette tapes are loaded in both DECKs 1 and 2, DECK 1 starts recording. With the RELAY button pressed, the unit enters the relay recording mode and DECK 1 starts recording at first.

CAUTION:

If the tape cannot be ejected after timer recording, set the TIMER selector to OFF and the KX-W900U's POWER switch ON; the tape can then be ejected.

MAINTENANCE**● Timer dual Recording**

1. Perform steps 1-3 of "Timer recording".
2. Set the TIMER selector to the DUAL REC position.
3. At the preset time, both DECKs start recording simultaneously.

● Timer Playback

1. All connections are the same as for timer recording.
2. Turn on the amplifier and adjust the Volume and Tone controls.
3. Set the input mode selector of your amplifier to the Tape mode.
4. Set the timer to the time you wish to start and stop playback.
5. Set the TIMER selector to the PLAY position.
6. At the preset time, the timer will turn power on to the amplifier and tape deck and begin playback. When the cassette tapes are loaded in both DECKs 1 and 2, DECK 1 starts playing. With the RELAY button pressed, the unit enters relay play mode and DECK 1 starts playing at first. It will shut power OFF, at the preset time as well ending playback.

After using your KX-W900U for a certain length of time, it is possible that the sound of your tapes may deteriorate with fading, vibration, or noise as a noticeable result. This is caused by an accumulation of dirt or dust on the heads, capstans, or pinch rollers, and magnetization of the heads. It is advisable to clean the capstan and pinch roller. Use a commonly available cotton swab and head cleaning solution to do this, or use a special head cleaning solution to do this, or use a special head cleaning tape. Head demagnetizers are also commonly available.

- When cleaning the heads, be careful not to apply unnecessary pressure.
- When demagnetizing the heads, be sure to follow the instructions of the head demagnetizer carefully.

KX-W900U

TROUBLESHOOTING

When your cassette deck fails to function properly, before assuming it is faulty, check the following troubleshooting list. It details the corrective action you can take yourself without having to call a service engineer. If you have any doubts or questions, get in touch with your nearest YAMAHA dealer.

Fault	Cause	Cure
Tape doesn't move in recording or playback.	<ul style="list-style-type: none"> ● Power plug not properly plugged in. 	<ul style="list-style-type: none"> ● Reinsert plug properly.
REC/PAUSE button fails to function.	<ul style="list-style-type: none"> ● No cassette tape loaded. ● Protective tab broken off. 	<ul style="list-style-type: none"> ● Load a cassette tape. ● Change to different tape, or cover the hole remaining after removal of tab with adhesive tape.
Sounds become faint and sometimes inaudible.	<ul style="list-style-type: none"> ● Head is dirty. ● Head is magnetized. ● Tape transport section dirty. 	<ul style="list-style-type: none"> ● Clean head using cleaning tape. ● Demagnetize head using head demagnetizer. ● Change to different tape.
Recorded sound is warped.	<ul style="list-style-type: none"> ● Tape is bad (stretched or deformed, etc.). ● Recording tape is itself warped. 	<ul style="list-style-type: none"> ● Replace with a fresh tape. ● As warping of tape itself cannot be rectified, replace with another tape and test.
Recorded sounds are distorted.	<ul style="list-style-type: none"> ● Recording level is too high. 	<ul style="list-style-type: none"> ● Check input level with meter and use lower rec level when recording.
Tape is playing back, but no sound is heard.	<ul style="list-style-type: none"> ● Faulty connection between deck and stereo amplifier. 	<ul style="list-style-type: none"> ● Rewire all connection from beginning.
Excessive noise.	<ul style="list-style-type: none"> ● Head is dirty. ● Head is magnetized. ● Worm out or poor quality tape. ● Connection(s) improperly made. ● Affected by external electrical noise. 	<ul style="list-style-type: none"> ● Clean head. ● Demagnetize head with head demagnetizer. ● Change to better tape. ● Check input and output connections and reinsert properly. ● Move away from electrical appliances (TV, fluorescent light, electric blanket, etc.)
Excessive wow (wavering of the sound).	<ul style="list-style-type: none"> ● Dirty capstan, pinch roller, etc., or poor tape. ● Tape is unevenly wound. 	<ul style="list-style-type: none"> ● Clean capstan, pinch roller, or change to better tape. ● Rewind tape.
Tape stops in the middle of recording or playback.	<ul style="list-style-type: none"> ● Slack tape, or tape spillage wound around capstan. 	<ul style="list-style-type: none"> ● Insert pencil in hole in cassette shell and turn to take up slack.

Fault	Cause	Cure
Fails to record.	<ul style="list-style-type: none"> ● REC LEVEL controls too low. ● Protective tabs broken off. 	<ul style="list-style-type: none"> ● Adjust REC LEVEL controls. ● Change tape or cover protective hole with adhesive tape.
Mute Search does not operate.	<ul style="list-style-type: none"> ● Recorded section is too short. ● Recorded section has low-level portions. ● Conversation, etc. has been recorded. 	<ul style="list-style-type: none"> ● Blank sections must be at least 4 seconds long.
High frequencies in the playback sound are emphasized and unpleasant to listen to, and noise level (hiss) is also high.	<ul style="list-style-type: none"> ● Dolby NR-recorded tape is played back in OFF position. 	<ul style="list-style-type: none"> ● Playback in appropriate Dolby NR position.
Playback sound is muffled and high frequencies are inaudible.	<ul style="list-style-type: none"> ● Normally-recorded tape is played back in DOLBY NR. ● Heads are dirty. ● Heads are magnetized. 	<ul style="list-style-type: none"> ● Playback in OFF position. ● Clean heads and carry out demagnetization with head demagnetizer.
When playing back tapes recorded on other decks, meter deflections are greater (smaller) than when recording.	<ul style="list-style-type: none"> ● Basic levels are different for different cassette decks. 	<ul style="list-style-type: none"> ● This is not a fault.
Does not operate when REC/ PAUSE button is pressed.	<ul style="list-style-type: none"> ● No cassette tape has been loaded. ● Protective accidental erasure tabs on cassette have been broken off. 	<ul style="list-style-type: none"> ● Load a cassette tape. ● Replace cassette tape, or cover tab holes with tape, etc.

KX-W900U

SPECIFICATIONS

Track Configuration	4 track, 2 channel recording and playback stereo twin Cassette Deck
Motor	DC servo motor x2 (capstan) DC motor x2 (reel)
Heads	Recording/Playback: Amorphous x2 Erase: Double Gap Ferrite x2
Rapid Transport (F.Fwd/Rew)	85 sec. (C-60)
Wow and Flutter	
WRMS	less than 0.05%
W.Peak	less than $\pm 0.08\%$
Signal-to-Noise Ratio (3rd harmonic distortion: weighted)	
Dolby NR off	better than 58 dB
Dolby B NR on	better than 66 dB
Dolby C NR on	better than 74 dB
Frequency response	
Normal tape (-20 dB)	20 — 17,000 Hz, ± 3 dB
CrO₂ tape (-20 dB)	20 — 19,000 Hz, ± 3 dB
Metal tape (-20 dB)	20 — 20,000 Hz, ± 3 dB

Harmonic Distortion (315 Hz, 3rd)

Normal tape	less than 1.0%
Chrome tape	less than 1.0%
Metal tape	less than 1.0%

Input Sensitivity/Impedance

Line	50 mV/50 k-ohms
-------------------	-----------------

Output Level

Line	360 mV/1 k-ohms
Headphones	0.3 mW/8 ohms

Channel Separation (3150 Hz)	40 dB
---	-------

Cross Talk (125 Hz)	55 dB
----------------------------------	-------

GENERAL

Power Supplies

U.S.A. and Canada models	120V, 60 Hz
---------------------------------------	-------------

Power Consumption	28W
--------------------------------	-----

Dimensions

(W x H x D)	435 x 132 x 305 mm (17-1/8" x 5-3/16" x 12")
--------------------------	---

Weight	7.0 kg (15 lbs. 7 oz.)
---------------------	------------------------

* Specifications subject to change without notice.

YAMAHA

VD82270-2 Printed in Japan BWgg, BBI® c

YAMAHA CORPORATION
10-1, Nakazawa-cho, Hamamatsu, 430 Japan